

**VOL: 1**  
**ISSUE: 2**  
**Year: 2015**

**ISSN: 2311-7982**



*The Malawi Journal of Applied Sciences  
and Innovation*

---



**The Polytechnic**

Editorial.....1

## Original Research

A critical appraisal of environmental impact assessment (EIA) in Malawi.....2  
*Wells Utembe*

An econometric analysis of sales volume against advertising and promotion: A case study of telecom networks Malawi LTD.....12  
*Geoffrey Chiyuzga Singini, Adamson Lyson Thengolose*

Investigating the process efficiency of flexigester as an on-site anaerobic faecal sludge sanitation system for application in emergency situations.....18  
*Flavius Kamwani, Bernard Thole, Katie Anderson, Grover H. Mamani Casilla, Jan Spit, Angus Gaisford*

Challenges and Opportunities in Using GIS for Monitoring and Management of HIV/AIDS: A Case Study from Malawi.....27  
*Brown Msiska and Patrick Chikumba*

Lead levels in lipsticks and eye shadows commonly sold in Blantyre city, Malawi.....37  
*W Utembe S.E Kaphika<sup>b</sup> and DD Lakudzala*

Sustainability of water kiosks in low- income areas of Blantyre city in Malawi.....44  
*A. Samson, P.N. Zuzani and U.B. Mughogho*

## Advertising

Centre for Water, Sanitation, Health and Appropriate Technology Development (WASHTED).....51

Master of Science in Infrastructure Development and Management.....53

## Information for Authors

MJASI Information for contributors.....54

**Editorial**

The Malawi Journal of Applied Sciences and Innovation is pleased to welcome our readers once again through this Volume 1 issue 2. This issue has articles on various research aspects covering the application of Geographic Information Systems (GIS) in health, on-site anaerobic faecal sludge treatment system, water supply in low-income areas, application of econometrics, appraisal of Environmental Management Assessment (EIA), and, safety of healthcare products.

The reader is also provided information on one of the five centres at Polytechnic, the Water Sanitation, Health and Appropriate Technology Development Centre (WASHTED). This issue also features the Faculty of the Built Environment (FoBE) and The Masters programme in Infrastructure Development (MSc. IDM).

MJASI cherishes being your partner in 2015 and is sincerely grateful to the editorial board members, our reviewers and all the authors. We, at MJASI, trust that through communicating science and scientific research, we enhance creation of an informed society for development.

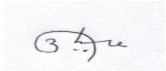

Bernard Thole, PhD, MSc, B.Ed.(Sci.)  
Editor-in-Chief



**Collaborating Partners**

Malawi Bureau of Standards  
The National Commission of Science and Technology

**Editorial Board**

Dr Paul Yillia	Vienna University of Technology, Australia
Mr StephenKuyeli	Malawi Bureau of Standards
Dr Paul Yillia	Vienna University of Technology, Austria
Dr Scott Evans	Harvard school of Public Health, USA
Mr HambaniGausi	National Commission of Science and Technology
Dr John Kauta	University Brunei, Darussalam, BRUNEI
Dr Scott Evans	Harvard School of Public Health, USA
Dr Henk J. Lubberding	Netherlands
Dr LupengaMphande	Ohio State University, Columbus, USA
Dr Damas A. Mashauri	University of Namibia School of Engineering, NAMIBIA

**Editorial Team**

Dr Bernard Thole	Editor-in-Chief
Mr Thengo Kavinya	Editorial Assistant
Mr Gift Khangamwa	Subject Editor Information and Communication Technologies
Mr Save Kumwenda	Subject Editor Environmental Health
Mr John Mwaonanji	Subject Editor Applied Mathematics and Statistics
Mr Ishmael Kosamu	Subject Editor Applied Physics and Biochemical Sciences.

**Correspondence**

Editor-in-Chief, MJASI, Polytechnic, P/B 303, Blantyre 3, Malawi. [mjasi@poly.ac.mw](mailto:mjasi@poly.ac.mw)

# A critical appraisal of environmental impact assessment (EIA) in Malawi

Wells Utembe

Department of physics and Biochemical Sciences, Malawi Polytechnic, +26588676157, wutembe@poly.ac.mw

## Abstract

Environmental impact assessment (EIA) was formally adopted in Malawi in 1996 to assess environmental effects of projects in a systematic, comprehensive and transparent manner. In order for EIA to contribute effectively to sustainable development in Malawi, it is necessary to periodically evaluate its performance. Therefore the EIA system in Malawi was evaluated using a framework developed by Wood in conjunction with the International Association for Impact Assessment's Principles of Environmental Impact Assessment Best Practice. The evaluation identifies a number of strengths and weaknesses. For instance, codification of EIA in legislation and preparation of EIA guidelines was a huge step in establishment of EIA in Malawi. EIA reports are required to cover significant impacts, alternatives and mitigation measures. There is right of appeal for third parties through the ministry or the courts whereas developers can only appeal through the yet-to-be established Environmental Appeals Tribunal. However, there are some areas that need improvement. For example, views of stakeholders are not sought at the screening stage, scoping reports or terms of reference are usually prepared by the competent authority, without consultation of other stakeholders; the public are not usually involved in the review process of the EIA reports, although this is legally provided for. There is need for more transparency in EIA follow-up. In conclusion, the EIA system in Malawi can be said to be operating effectively. However, in order to enhance the contribution of EIA to sustainable development in Malawi it is important to address these shortcomings.

Keywords: Environmental impact assessment, scoping, screening, transparency, public consultation, efficiency

## 1.0 Introduction

Environmental Impact assessment (EIA) is defined as a process of identifying, predicting, evaluating and mitigating biophysical, social, and other relevant effects of development proposals prior to major decisions being taken and commitments being made (IAIA, 1999). Since its introduction in United States of America (USA) in 1969, EIA has been adopted worldwide to consider the environmental effects of projects, plans and programmes in a systematic and comprehensive and transparent manner. EIA has been practiced in Malawi for a few decades. EIA was first codified in Malawian legislation in 1996, with the enactment of the Environment Management Act (EMA, no 23 of 1996). Prior to this, a number of EIAs were only done on the insistence of international money lending organizations and donors, a common experience in most African countries (Marara et al., 2010). The EIA system in Malawi comprises of a framework of environmental laws and a set of more detailed administrative procedures or technical guidelines.

The main purpose of EIA is to make sure that environmental considerations are adequately addressed before a project with potential significant negative impacts is authorized. Consequently, EIA can contribute significantly to sustainable development. (Rees, 1988, Kozlowski, 1990, UNCED, 1992), defined as 'development that meets the needs of present generations without compromising the ability of future generations to meet their needs' (Brundland, 1987). However, in order for EIA to contribute effectively to sustainable development in a particular country, it is necessary to periodically evaluate the EIA system (Emmelin, 1998).

Many criteria and evaluation systems have been used in many countries to evaluate the effectiveness of EIA systems. These sets of criteria evaluate the performance of EIA from a number of perspectives or dimensions. The first dimension identifies a distinction between studies of EIA systems structures, focusing on the design of the administrative process, and on the one hand and of implementation structures, focusing on outcomes by evaluating the impact that EIA has had on actual environmental performance (Annandale, 2001; Emmelin, 1998). Noting that any EIA system has a theoretical side in the sense that it is designed to operate on certain principles and a practical side on how it operates the second approach to EIA evaluation could be called the dichotomy between "theory" and "practice" (Emmelin, 1998) using two distinct types of evaluation. The first category involves the evaluation of EIA systems against a more or less explicit ideal. International comparisons of EIA-systems by Wood (2003) fall into this category. In the second category documents such as EIA reports are compared against criteria for good documents or good practice in ex ante evaluations. The third category deals with the function or practical implementation of EIA of the system based on surveys, interviews and other statements. The final category of evaluation approaches involves an attempt to understand the functioning of the EIA system, and the quality of processes and documents, in the context of organizational and professional culture (Annandale, 2001; Emmelin, 1998). This study largely utilized criteria developed by Wood (2003), which belongs to the first category.

In Malawi a number of authors have also tackled the issue of EIA effectiveness: The quality of EIA reports was assessed in by Mhango (2005) while Kosamu (2011) analysed the application of EIA to infrastructural projects in Malawi and there is some unpublished work where the performance of EIA in Malawi was compared with that of South Africa (Harrison, 2005). This paper describes the Malawian EIA system and assesses the performance of EIA system using evaluation criteria as proposed by Wood (2003) and the International Association for Impact Assessment's Principles of Environmental Impact Assessment Best Practice (IAIA, 1999). The main difference between this work and earlier studies is the nature of criteria used. The criteria used by Mhango (2005) and Kosamu (2011) involve assessment of the quality of the EIA reports. The criteria used in this study do not involve the study of the quality of EIA reports but involves analysis of EIA systems (laws, regulations, requirements and the approval process) against internationally recognized standards of best practice. As a conclusion, the paper gives a number of recommendations for the effective implementation of EIA in Malawi.

## 2.0 Methodology

This assessment is a critical narrative review using descriptive analytical criteria developed by Wood (2003) and later adopted by Annandale (2001). These criteria are used in conjunction with the International Association for Impact Assessment's Principles of Environmental Impact Assessment Best Practice (IAIA, 1999). These criteria were chosen also because they have been widely applied in many countries and because they are easy to adapt and flexible (Toro et al 2010). Various combinations of these criteria have been used to evaluate EIA systems in many countries including Columbia (Toro et al 2010), United States of America, the United Kingdom, the Netherlands, New Zealand (Wood, 2003), Western Australia (Wood, 1994), Maldives (Annandale, 2001), Egypt, Turkey and Tunisia (Ahmad & Wood, 2002), South Africa (Wood, 1999) and many other countries.

The criteria by Wood (2003), later adopted by Annandale (2001) are derived from an analysis of the stages in the EIA process, plus an additional criterion on administrative support. These criteria are given in Box 1 below.

The Principles of Environmental Impact Assessment Best Practice demand that EIA should be purposive, rigorous, practical, relevant, cost-effective, efficient, focused, adaptive, participative, interdisciplinary, credible, integrated, transparent and systematic (IAIA, 1999). Please refer to the document for the actual definitions of these terms. The performance of the Malawian EIA system was assessed against the criteria by Wood (2003) in conjunction with the Principles of Environmental Impact Assessment Best Practice (IAIA, 1999). The author used these criteria by studying relevant and guidelines and also through the use of his experience with EIA in Malawi.

### **Box 1: Criteria used to assess performance of an EIA system based on Wood (2003) and Annandale (2001),**

#### **1 Evaluative principles**

- a. Is the system based on clear legal provisions?
- b. Does the EIA system rest on detailed administrative procedures/ guidelines?
- c. Must the relevant environmental impacts of all significant actions be assessed?
- d. Is there a broad and open process of proposal referral?

#### **2 Preliminary assessment**

- a. Does the EIA system require the analysis of alternatives?
- b. Does the EIA system provide a mechanism for screening of actions for environmental significance?
- c. Does the EIA system require that the scoping of environmental impacts of actions take place?

#### **3 Detailed assessment**

- a. Does the EIA system require that reports meet prescribed content requirements?
- b. Do checks on content (by Government assessing agencies) occur before publication of the proponent's EIA study?

#### **4 EIA study review**

- a. Are the EIA studies presented for public review, and is the proponent required to respond to issues raised?

#### **5 Decision making**

- a. Is the decision-making process of Government transparent?

- b. Is the decision, and the reasons for it, published?
- c. Do these reasons include an explanation of how the EIA report and review influenced the decision?
- d. Does the EIA system require that legally binding conditions be set?
- e. Does the law/administrative procedures allow for a decision to be postponed until an EIA report has been prepared and reviewed?

#### 5 Follow-up

- a. Does the EIA system require post-approval monitoring of action impacts to be undertaken?
- b. Does the EIA system require that mitigation of action impacts be considered at various stages of the EIA process?
- c. Is there a process for auditing proponents' commitments?
- d. Is there a process for monitoring and auditing the EIA system as a whole?

#### 6 Administrative support

- a. Is the EIA system given adequate resources?
- b. Do existing staff have the appropriate skills to operate the EIA system?
- c. Does a well-qualified, private local consulting sector exist?
- d. Is the 'across-Government' environmental administrative system supportive of EIA?

### 3.0 The EIA process in Malawi

In Malawi the main piece of legislation that regulates EIA is the Environment Management Act (EMA No 23 of 1996). According to the Act, "a developer shall not start a prescribed project or a licensing authority shall not issue a license to a developer concerning a prescribed project unless an EIA approval has been issued by the minister".

The competent authority for EIA in Malawi, the Environmental Affairs Department (EAD), has produced a number of EIA guidelines which include EIA Guidelines (EAD, 1997), EIA Guidelines for Irrigation Projects (EAD, 2002a), EIA guidelines for Mining projects (EAD, 2002b), EIA guidelines for sanitation projects (EAD, 2002c).

If a developer is considering a prescribed project, they are required to submit a project brief which states the purpose of the project, location, preliminary design, stage of project in project cycle, and any alternatives under consideration. The Director of EAD refers the Project Brief to the Technical Committee on the Environment (TCE) which assesses the project using set screening criteria. The TCE is a committee composed of technical people from various government departments and academia, established under section 16 of the EMA.

The TCE then recommends to the director whether the action requires a full EIA or not.

If EIA is required for the project the EIA guidelines require that the developer should proceed to the scoping process in which the EIA team produces terms of reference (TORs) based on consultation with stake holders. The TORs are then sent to the director of EAD for approval. This is requirement of the guidelines.

The EIA team then prepares the report according to the TORs in consultation with all stakeholders. The report is reviewed by the TCE, before it is reviewed by the National Council on Environment (NCE). The NCE advises the director of EAD on the necessary action which may be to allow the project to proceed (with or without conditions) or not, or to seek more information from the developer. The NCE is a committee made of heads of government agencies, Council established under section 10 (1) of EMA whose main role is to focus on the policy implications of carrying out projects. Involvement of multi-disciplinary interagency teams in the EIA review can make the EIA process more rigorous and credible.

**Figure 1 below presents the EIA process in Malawi. In the next few sections the performance of the EIA system in Malawi is presented. The results are summarized in table 1 below.**

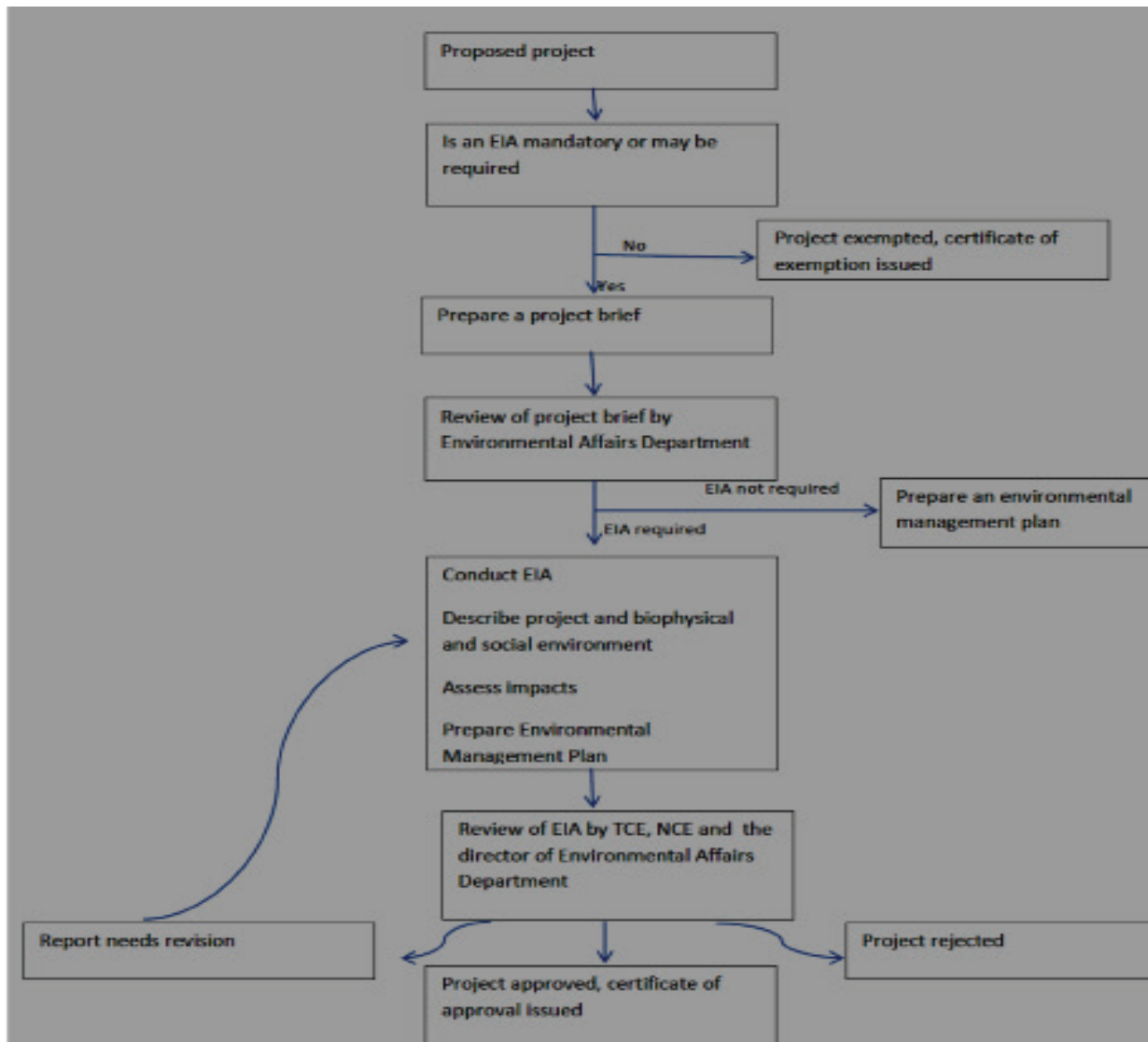

### 3.1 Legal basis

According to criterion 1a in Box 1, an effective EIA system should be based on clear legal provisions. The Environment Management Act (1996, c 23) stipulates the nature of projects that should undergo EIA, how proposed projects are referred to the Director of EAD, and the concise contents of the project brief, the EIA report and the decisions that can be made by the director of EAD. Although the Act gives this information, much detail is covered in the EIA guidelines to which the Act gives powers to the minister to produce and amend from time to time. This set up is flexible since the guidelines can be changed easily as compared to the Act which has to go through parliament.

As discussed in the next few sections, the EMA gives provisions for a number of the stages in the EIA process. EIA monitoring and auditing are conspicuously absent in the EMA.

### 3.2 Coverage

In the EMA a project is defined as development activity or proposal which has or is likely to have an impact on the environment. The list of prescribed projects includes major policy reforms such as degazettement of forestry reserves, changes to zoning plans and proposed introduction of exotic species (EAD, 1997). So far EIA has been applied entirely to projects.

It is widely accepted that project EIAs do not adequately consider the cumulative impacts caused by several projects or even by one project's subcomponents (Alshuwaikhat, 2005). The principal reasons are that EIA starts too late, ends too soon, and is too site-specific (Shepherd & Ortolano, 1996). These shortcomings can

be overcome by strategic environmental assessment (SEA) which is defined as the formalized, systematic and comprehensive process of evaluating the environmental impacts of a policy, plan or program and its alternatives (Therivel et al, 1992). Malawi does not yet have SEA. Therefore, project-level EIA's limited scope should be expanded to higher-level assessments of policies, plans, and programs.

### **3.3 Analysis of the screening system**

The screening system in Malawi comprises of an objective inclusive list with criteria for all projects for which EIA is mandatory and a subjective list of projects for which EIA may be required and screening criteria to be used with the subjective list (EAD, 1997). The use of both subjectivity and objectivity can be said to be a strength of the Malawian system as subjectivity in EIA provides some form of flexibility, which according to Wood (2003), ensures that the EIA system is focused on the desired outcomes of EIA rather than ensuring that all procedural formalities have been completed.

Views of stakeholders are not sought at the screening stage in Malawi. There is no requirement for disclosure of projects that are being considered for EIA and similarly, screening decisions are not published. This setup is not very transparent. However, not involving the public at the screening stage may make the process more efficient and cost-effective. An efficient EIA system imposes minimum cost burdens on proponents and participants consistent with meeting accepted requirements and objectives of EIA (IAIA, 1999). This notwithstanding, exclusion of stakeholder involvement at the screening stage may prove more costly if some stakeholders choose to fight against results of screening decisions either in court or otherwise.

### **3.4 Scoping in the Malawian EIA system**

Scoping is defined as a process of determining, from all of a project's possible impacts and from all the alternatives that could be addressed, those that are key and significant (Glasson et al, 1999). It is a vital stage in the EIA process in that failure to scope an EIA effectively creates the risk that unnecessary work will be undertaken, or that the significant consequences are missed (Snell & Cowell, 2006).

According to the EIA guidelines scoping is supposed to be carried out by the EIA team with the terms of reference sent for approval to the EAD. But according to the observation of the author, for types of projects with which EAD staff are very familiar, the TORs are prepared by the EAD without consultation of other stakeholders. Standard TORs are used in such cases. For this reason some people have commented that scoping is a poorly performed component of the Malawian EIA system, with 73 percent of the EIAs failing to satisfy any of its requirements (Mhango, 2005).

EIA developers may prefer the case where TORs are provided by the EAD as this reduces their work and time (Snell & Cowell, 2006). In addition, it may be argued that, after all the EIA team will meet the stakeholders during the consultation meetings and any issues that were left out of the TORs will be encountered at that time. On the other hand, one can also argue that producing TORs without consulting affected parties is not participative, transparent or credible and therefore does not meet the IAIA's EIA best practice principles.

### **3.5 EIA report content**

The content of the EIA report is given in the EMA and expounded in the EIA guidelines. The guidelines do not only indicate the content of the EIA report but also the areas that EIA reviewers will have to concentrate on. The review topics, and thus report content, are organized into four review Areas, including Description of the project, the local environment and the baseline conditions, Identification, analysis and assessment of impacts, Consideration of alternatives and impact mitigation and Communication of the results (EAD, 1997).

It is good that the guidelines insist on alternatives and mitigation of impacts. Since costs of various alternatives vary for different groups of people and for different environmental components (Wood, 2003). Therefore, proper selection of alternatives can reduce environmental degradation and/or minimize the cost of actions (Toro et al., 2010).

In Malawian EIA mitigation of impacts is compulsory in a distinct section of the report called Environmental Management Plan (EMP). Mitigation of impacts can be in form of avoidance at source, minimization at source, abatement on site, abatement at receptor, repair, compensation in-kind and other compensation and enhancement (Wood, 2003).

### **3.6 EIA review and decision making in the Malawian system**

In Malawi, EIA reports are rigorously reviewed by the TCE, the NCE and the director of EAD, with reports often been sent back to EIA teams for revision. The Involvement of multi-disciplinary interagency teams in the EIA



review can make the EIA process more rigorous and credible.

The review process can also be said to be somewhat transparent in that the main areas that reviewers focus on are discussed in the EIA guidelines. However, review notes from the review meetings are not published.

Section 26 of the EMA says that the director shall invite comments from the public. This is rarely done. Exclusion of the public in the EIA review may substantially reduce costs and time. On the other hand, the desire to save time and resources may sometimes backfire and cause more delays and expenses when some stakeholders challenge the contents of the report later.

When the director decides that the EIA report should undergo public review, an announcement is made in mass media and copies of the draft report are put in public and university libraries. Copies of the EIA report are also sent to relevant government agencies for comment. It may be recommended further that copies should be available for purchase at a reasonable price.

There are concerns on utilizing EIA reviewers who are also EIA consultants. Although these reviewers are not allowed to be present during the review of EIA reports that they helped prepare, still there are questions regarding objectivity. These observations are also made by Glasson et al (1999). For instance, will a reviewer remain objective when reviewing a report in which he took a consultancy bid and lost? Can reviewers not deliberately be failing other consultant's EIA reports to portray them as incompetent in the eyes of developers? However, involvement of EIA consultants in EIA review is not unique to Malawi (Branis, 1994; Wood, 2003). The alternative is to use internal reviewers, an option that requires recruitment of more staff.

The Malawian EIA system does appear to have provisions for appeal. The Environmental Affairs Tribunal (EAT) is mandated to consider appeals against any action of the minister, director or inspector under this Act (GOM, 1996). Any person aggrieved with the decision of the Tribunal may appeal to the High Court. The EAT is yet to be established and appeals are currently sent to the minister responsible for environment. This has limitations to access to justice.

### **3.7 Public participation**

Public participation is an integral part of the EIA system in Malawi provided for in the EMA. However, the public are not involved in the screening process and are rarely involved in the scoping process and EIA review. In addition, for people who stay far from areas surrounding project sites, participation is reduced to information about the project, if at all, since public notification of EIA decisions are not done formally.

The EMA stipulates that EIA reports should be available for public inspection. An individual can have access to any report at the EAD head offices in Lilongwe, the capital City of the Malawi. Still there are questions as to whether this is accessible enough for people who live very far from EAD offices. Wood (2003) also comments that equity demands that EIA reports be obtainable at a reasonable fee for detailed perusal.

There are also issues of language as EIA reports including non-technical summaries are written in English. Public participation should not only mean being consulted earlier in the EIA process but should also mean being able to have access to the content of the EIA report upon which the decision to allow or not to allow the project was based.

### **3.8 EIA follow-up in the Malawian system**

EIA follow-up, also known as monitoring or post-development audit is defined as the evaluation of the impacts of a project or plan (that has been subject to EIA) for management of, and communication about, the environmental performance of that project or plan (Morrison-Saunders & Arts, 2004). It tests the accuracy of impact predictions and the effectiveness of mitigation measures (Lawrence, 2003).

Wood (2003) recommends requirement of inclusion of a monitoring programme in the EIA, publishing of monitoring and auditing results, a public right to appeal if monitoring results are unsatisfactory, existence of a published guidance on monitoring and auditing and requirement for comparison of predictions with monitoring results in EIA follow-up.

The EMA does not address EIA follow-up. However, the EIA guidelines do require inclusion of monitoring and a monitoring programme in the EIA report. Despite this, according to Kosamu (2011), once a license is issued, there is very little control of EIA requirements and/or conditions in Malawi. It is not clear what the competent

authority does as part of EIA follow-up and what they do with the findings. As a result of not having EIA monitoring and auditing in the EMA, monitoring of impacts may not be systematically performed for all prescribed projects.

In addition to the monitoring of the EIA projects, EIA systems should also be monitored (Wood, 2003). Although the National Environmental Policy (2006) requires the review of some components of the EIA system there is no indication that this is being done.

### 3.9 Administrative support

In the past decade lack of well-qualified EIA practitioners has been reported as a serious constraint to effective EIA performance in Malawi (Kosamu, 2011). It is said that there were environmental units with no technical or clerical/support staff to manage the EIA process adequately. But now with EIA being offered as a course at Malawi Polytechnic and Chancellor College, constituent colleges of the University of Malawi, that problem no longer exists. Graduates of these colleges are employed by government agencies, including the EAD, and the private sector, which include the local consulting sector. However, although there are available experts with formal training in EIA, there may be shortcomings in capacity and experience in areas such as quantitative impact prediction methods and use of models.

Underfunding is an endemic challenge in all government departments in Malawi, and the EAD is not an exception. However, participation of the statutory inter-agency committees such as TCE and NCE in EIA shows that there is 'across-government environmental administrative system supportive of EIA in Malawi.

**Table 1: Summary of performance of the Malawian EIA system (section 3.1-3.9) based on criteria by Wood (2003) and Annandale (2001)**

Evaluative principles	Rating	Comment
Is the system based on clear legal provisions?	Yes	The EMA has a distinct clear section on EIA
Does the EIA system rest on detailed administrative procedures/guidelines?	Yes	The EAD has produced a number of sectoral EIA guidelines
Must the relevant environmental impacts of all significant actions be assessed?	Yes	Coverage of all environmentally significant projects except for policies, plans and programmes
Is there a broad and open process of proposal referral?	Partially	The process is clear for some licensing agencies but not for all stakeholders
<b>Preliminary assessment</b>		
Does the EIA system require the analysis of alternatives?	Yes	Available alternative technologies, methods or processes and reasons for not employing the alternative technologies, methods or processes must be discussed
Does the EIA system provide a mechanism for screening of actions for environmental significance?	Yes	The proponent is required to submit a project brief for the screening process
Does the EIA system require that the scoping of environmental impacts of actions take place?	No	The EMA does not address scoping. Scoping is rarely conducted for each project although it is a requirement in the guidelines. Standard TORs are often issued for most projects.

<b>Detailed assessment</b>		
Does the EIA system require that reports meet prescribed content requirements?	Yes	The laws on EIA has some requirements which are expounded in the guidelines
Do checks on content (by Government assessing agencies) occur before publication of the proponent's EIA study?	No	No checks are undertaken or required and the reports are rarely published
<b>EIA study review</b>		
Are the EIA studies presented for public review, and is the proponent required to respond to issues raised?	Yes and No	The Director of EAD rarely invites comments from the public as required by the EMA.
<b>Decision making</b>		
Is the decision-making process of Government transparent?	Partially	The EIA guidelines give criteria that are used to review the report but criteria for decision making are not given
Is the decision, and the reasons for it, published?	No	No provision is made for publication of final decisions about proposals
Do these reasons include an explanation of how the EIA report and review influenced the decision?	No	Reasons for decision are not published
Does the EIA system require that legally binding conditions be set?	No	No mention is made of conditions for approval
Does the law/administrative procedures allow for a decision to be postponed until an EIA report has been prepared and reviewed?	Yes	The EMA requires a license be withheld until an EIA report has been approved
<b>Follow-up</b>		
Does the EIA system require post-approval monitoring of action impacts to be undertaken?	No	The EMA does not address EIA follow up
Does the EIA system require that mitigation of action impacts be considered at various stages of the EIA process?	Partially	The EIA report has an Environmental management programme (EMP) section that includes mitigation of impacts
Is there a process for auditing proponents' commitments?	No	No mention is made of either proponent commitments or auditing follow-up by the EAD

Is there a process for monitoring and auditing the EIA system as a whole?	No	No mention is made of this EMA although the EIA report should have a section on a monitoring programme
<b>Administrative support</b>		
Is the EIA system given adequate resources?	No	The EAD does not have enough staff for EIA implementation, evaluation and monitoring.
Do existing staff have the appropriate skills to operate the EIA system?	Partially	Collectively, the EAD, TCE and NCE have the skills to make the EIA system work but since EIA deals with a wide range of project activities, there are times when they need external help
Does a well-qualified, private local consulting sector exist?	Partially	EIA is taught in a number of tertiary institutions but a quick look at EIA reports reveals lack of predictive skills most especially the area of predictive modeling
Is the 'across-Government' environmental administrative system supportive of EIA?	Yes	Other government agencies, including licensing agencies, offer support in EIA

The evaluation of the Malawian EIA system has identified a number of strengths and weaknesses, as well as a number of areas of opportunity for potential improvements. Codification of EIA in legislation and preparation of EIA guidelines was a huge step in establishment of EIA in Malawi; EIA reports are required to cover significant impacts, alternatives and mitigation measures; there is right of appeal for third parties through the ministry or the courts whereas developers can only appeal through the yet-to-be established Environmental Appeals Tribunal. However, there are areas that need improvement. For example, it is necessary to consider seeking views of stakeholders during screening and to ask developers to publish notification of intent; there is need to improve accessibility to EIA reports to the public; there is need to improve EIA review through involvement of the public and publishing of review outcomes; there is need to clarify guidelines used in EIA follow-up; and the Environmental Affairs Tribunal should be established to provide access to justice to proponents

#### 4.0 Conclusion

This study has evaluated the EIA system in Malawi using criteria from Wood and the IAIA's Principles of Environmental Impact Assessment Best Practice. According to these criteria, the Malawian EIA system has a number of strengths and weaknesses. EIA and some of its constituent steps are a legal requirement in Malawi for prescribed projects. There is right of appeal for third parties through the ministry or the courts. On the other hand, there are some weaknesses in the system: Views of stakeholders are not sought at the screening stage, scoping reports or terms of reference are usually prepared by the competent authority, without consultation of other stakeholders; the public are not usually involved in the review process of the EIA reports, although this is legally provided for. There is need for more transparency in EIA follow-up. Malawi should also finalize the establishment of the Environmental Affairs Tribunal for right of appeal of developers. In conclusion, the EIA system in Malawi can be said to be operating effectively. However, in order to enhance the contribution of EIA to sustainable development in Malawi it is important to address the shortcomings

#### References

1. Ahmad, B., & Wood, C. 2002. A comparative evaluation of the EIA systems in Egypt, Turkey and Tunisia. *Environmental Impact Assessment Review*, 22: 213–234.
2. Alshuwaikhat, H. M. 2005. Strategic environmental assessment can help solve environmental impact assessment failures in developing countries. *Environmental Impact Assessment Review*, 25: 307–317.
3. Annandale, D. 2001. Developing and evaluating environmental impact assessment systems for small developing countries. *Impact Assessment and Project Appraisal*, 19(3): 187-193.

4. Branis, M. 1994. A system of certified environmental impact assessment experts in the czech republic. *Environ Impact Assess Rev*, 14: 203-208.
5. Brundtland, G. H. 1987. *Our common future*, Oxford, Oxford University Press
6. EAD. 1997. *Environmental Impact Assessment Guidelines*. Lilongwe.
7. EAD. 2002a. *Environmental Impact Assessment Guidelines for Irrigation Projects*. Lilongwe.
8. EAD. 2002b. *Environmental Impact Assessment guidelines for Mining projects* Lilongwe.
9. EAD. 2002c. *Environmental Impact Assessment guidelines for sanitation projects* Lilongwe.
10. Emmelin, L. 1998. Evaluating environmental impact assessment systems, part 1: Theoretical and methodological considerations. *Scandinavian Housing and Planning Research*, 15(3): 129-148.
11. Glasson, J., Therivel, R., & Chadwick, A. 1999. *Introduction to environmental impact assessment*, 2nd edn, 1999 (Second ed.): UCL Press.
12. GOM. 1996. *Environment management Act*, 23.
13. Harrison, M. A. C. 2005. *A comparison of the environmental impact assessment legislation of south africa and Malawi*. North-West University (Potchefstroom Campus).
14. IAIA, 1999, *Principles of Environmental Impact Assessment Best Practice*, viewed at 21 January 2015 <available at : [http://www.iaia.org/publicdocuments/special-publications/Principles%20of%20IA\\_web.pdf](http://www.iaia.org/publicdocuments/special-publications/Principles%20of%20IA_web.pdf)>
15. Kosamu, I.B.M, 2011. Environmental impact assessment application in infrastructural projects in Malawi, *Sustainability Science*, 6: 51–57
16. Kozlowski, J.M. 1990. Sustainable development in professional planning: a potential contribution of the EIA and UET concepts. *Landscape and Urban Planning*, 19(4): 307- 332.
17. Lawrence, D. P. 2003. *Environmental Impact Assessment: Practical Solutions to Recurrent Problems*. New Jersey: John Wiley & Sons.
18. Marara, M., Okello, N., Kuhanwa, Z., Douven, W., Beevers, L., & Leentvaar, J. 2010. The importance of context in delivering effective EIA: Case studies from East Africa. *Environmental Impact Assessment Review* 31(3): 286-296
19. Mhango, S. D. 2005. The quality of environmental impact assessment in Malawi: a retrospective analysis. *Development Southern Africa* 22(3): 383-407.
20. Morrison-Saunders, A., & Arts, J. 2004. Introduction to EIA follow-up. In Morrison-Saunders, & Arts (Eds.), *Assessing Impact: Handbook of EIA and SEA Follow-up*. London: Earthscan.
21. Rees, W.E. 1988. A role for environmental assessment in achieving sustainable development. *Environmental Impact Assessment Review*, 8(4): 273-291.
22. Shepherd, A., & Ortolano, L. 1996. Strategic environmental assessment for sustainable urban development. *Environ Impact Assess Rev*, 16: 321-335.
23. Snell, T., & Cowell, R. 2006. Scoping in environmental impact assessment: Balancing precaution and efficiency? *Environmental Impact Assessment Review*, 26(4): 359-376.
24. Therivel, R., Wilson, E., Thompson, S., Heaney, D., & Pritchard, D. 1992. *Strategic environmental assessment*. London: Earthscan.
25. Toro, J., Requena, I., & Zamorano, M. 2010. Environmental impact assessment in Colombia: Critical analysis and proposals for improvement. *Environmental Impact Assessment Review*, 30: 247–261.
26. UNCED (United Nations Conference on Environment and Development, 1992 *The Rio Declaration On Environment And Development* (online), Viewed 21 January 2015, <Available at: <http://www.un.org/documents/ga/conf151/aconf15126-1annex1.htm>>n
27. Wood, C. 1994. Predominance and independence in environmental Impact Assessment: The western australian model. *Environm Impact Assess Rev*, 14: 37-59.
28. Wood, C. 1999. Pastiche or postiche? Environmental impact assessment in South Africa. *South African Geographical Journal*, 81(1): 52-59.
29. Wood, C. 2003. *Environmental Impact Assessment: a comparative review* (second ed.). London: Pearson Education Limited.

# AN ECONOMETRIC ANALYSIS OF SALES VOLUME AGAINST ADVERTISING AND PROMOTION: A CASE STUDY OF TELECOM NETWORKS MALAWI LTD

Geoffrey Chiyuzga Singini<sup>a</sup>, Adamson Lyson Thengolose<sup>b\*</sup>

<sup>a</sup> Tiwalere OVC Project, Feed The Children Inc., P.O Box 31611, Lilongwe 3, Malawi

<sup>b</sup> Mathematics and Statistics Department, University of Malawi – The Polytechnic, P/B 303, Chichiri, Blantyre 3, Malawi

\*Corresponding author. Mathematics and Statistics Department, University of Malawi – The Polytechnic, P/BAG 303, Chichiri, Blantyre 3, Malawi. Email: athengo@gmail.com, Tel.: +265 999 941 432

## Abstract

The absence of efficient information flows, adequate regulation and market transparency has led most of the Malawian profit making companies to be very susceptible to high volatility and risk. An efficient company attracts more investors, which translate into company liquidity and enhance economic growth. In this paper an analysis of the relationship among sales volume, advertising costs, and cost of promotions is carried out to provide insights on the performance of any profit making company on the local market. Time series data from Telecom Networks Malawi (TNM) Ltd are used to build a model for forecasting sales volume for TNM basing on advertising and promotion costs, while controlling other variables. Analysis of the model shows that the prediction model is a better approach in forecasting sales volume than the naive method. It is also shown that there exists multicollinearity between advertising cost and promotion cost.

Keywords: Telecom Networks Malawi; Sales volume; Advertising cost; Promotion cost.

## 1.0 Introduction

Trade promotion is a key activity in every marketing plan and econometric models have produced striding results in helping researchers in marketing predicting sales in the short and long term instances by employing promotion schemes which effectively increase the customer awareness of the business and its products. Though the response of consumers to trade promotions is not straight forward and has been debatable, non-linear models have been used to ably simulate the response of customers and provide a good understanding of the impact of trade promotion at generating incremental volumes. Through the models, estimates of the volume are generated per promotion event in each of the different retail outlets by region and identify the most and least effective trade channels. With detailed spend information available, econometric analysis comes into play to compare the Return on Investment (ROI) of various trade activities such as Every Day Low Price and Off-Shelf Display; and optimizes the trade plan by choosing the most effective trade channels and targeting the most effective promotion activity (Armstrong, 1970).

In marketing research and pricing system, econometric models have provided evidence that price change of the brand impacts negatively on sales. This effect captured through Market Mix Modeling, builds on price elasticity of the brand which exposes the percentage change in the sales for each corresponding percentage change in price. This knowledge of econometric modelling, equip marketing managers to evaluate the impact of a price change decision (Tice, 2008)

Undisputedly, when a new product is launched, the associated publicity and promotions typically results in higher volume generation than expected. However, there are some extra volumes that cannot be completely captured in the model using the most general econometric models. In such scenarios special variables to capture this incremental effect of launches should be applied (Schuler & Wallin, 1983). The combination of such variables and those of marketing efforts associated with the launch would give the total launch contribution is warranted in order to build a reliable and validated econometric model. With such information handy, different launches can be compared by calculating their effectiveness and ROI (Tice, 2008).

Econometric analysis methods have contributed tremendously in studying competition through market mix models (MMM). Overall, a wide range of knowledge indicates that the impact of competition on the brand sales should be captured by creating the competition variables accordingly in order to simulate a real life situation of the model (Parsons, 2004; DelVecchio, et. al., 2006). The variables may be created from the marketing activities of the competition like television advertising, trade promotions and product launches. The resulting model should be used to identify the biggest threat to own brand sales from competition. The cross-price elasticity and the cross-promotional elasticity play a major role in devising appropriate response to competition tactics. Suffice to say, a successful competitive campaign is a major input in such analysis to learn valuable lesson for owning a brand (Jordan, 2008).

Some MMM studies on profit making companies in the SADC region have concentrated on testing efficiency, consistency, volatility and returns, and integration with other companies. Others have tried to address the role of

these companies in economic development of the nation. The absence of efficient information flows, adequate regulation and market transparency leads Malawian profit making companies to be very susceptible to high volatility and risk. An efficient company attracts more investors, which translate into company liquidity and enhance economic growth (MIPA, 2008).

Malawi, known to be one of the poorest countries, both socially and economically, in the world; has had two mobile phone companies for more than ten years but still lags behind in her economic developments as compared to other developing countries within the SADC region. Efficiency of the company in this field implies making good profits. This boosts investor confidence and can enhance growth by mitigating moral hazard and consequently increasing productivity (MIPA, 2008).

Many companies in the developed countries have used econometric models to explain the behaviour of sales volume and other variables in their companies (Persaran, et. al., 1992), which is not the case with Malawian companies. Malawian companies have a lot of potential to grow but lack efficient and reliable decision making tools and the approach of using models that could bail most companies out of this state. Therefore, this paper reports on efforts to extend the application of econometric models in mobile phone companies in Malawi. This is achieved by determining whether an econometric analysis of the sales volume against cost of promotion and amount spent on advertising is an efficient way of explaining the sales volume behaviour in mobile phone companies.

## 2.0 Materials and methods

### 2.1 Data collection

Telecom Networks Malawi Limited (TNM) was chosen as a case study and all the data were collected from its headquarters in Blantyre. The services provided by TNM include sim cards, recharge vouchers, and cell phones, among others. The data collected included the amount of money spent on sales volume, advertising, and promotion from 1997 to 2007 (see Table 1)

Year	Advertising Cost in MK (10 <sup>6</sup> )	Promotion Cost in MK (10 <sup>6</sup> )	Sales Volume in MK (10 <sup>6</sup> )	Number of Promotions
1997	8.90	5.10	363	1
1998	10.90	6.40	373	2
1999	11.20	7.70	389	2
2000	11.00	8.00	448	2
2001	12.10	9.10	588	1
2002	12.30	9.80	689	2
2003	14.70	11.00	851	2
2004	16.00	11.00	878	3
2005	16.40	12.30	926	2
2006	18.90	14.00	1,000	3
2007	21.00	18.00	1,010	3

### 2.1 Model Components

The selected model for this study is the multiple linear regression model, with two explanatory variables (Miles & Shavlin, 2001) and thus the model is:  $y = \beta_0 + \beta_1 x_1 + \beta_2 x_2 + e$

where the dependent variable = sales volume, the independent variables are = advertising cost and = cost of promotion, and = error term

It should be noted that the sales volume figures are for all the products and services offered by TNM. The model precisely defines sales volume in terms of variables that help explain its behaviour from the customer point of view. This is one way of obtaining information about the goods and services offered by the company to the public. In this model, the advertising cost covers all forms of advertising the company conducted in the eleven year period. Cost of promotion is included because TNM uses promotions to reach out its customers.

Considering that sales volume could not only be explained by the two independent variables but also by other

variables, which are accounted for by the random error term.

The model (1) is estimated by least squares, which yields parameter estimates such that the sum of squares of errors is minimized. The resulting prediction equation is:  $\hat{y} = \hat{\beta}_0 + \hat{\beta}_1x_1 + \hat{\beta}_2x_2$

where the variables are defined as in (1) except that “^” denotes estimated values.

## 2.2 Data Analysis

The data set in Table 1 was split into two: modelling and verification data. Data from 1997 to 2003 was used as modelling data, and data from 2004 to 2007 was used as verification data. This was done to verify the effectiveness and validity of the model. It was done to test if the model worked to the best of the company data that was obtained.

The process of model building was done by using SPSS to come up with descriptive statistics, normality test, skewness and kurtosis analysis. Their U statistics was used to assess predictive accuracy and to avoid obvious scaling problems involved with predictive accuracy measures (Greene, 2003).

## 3.0 Results and Discussions

Table 2 shows the descriptive statistics for the data set. The table indicates that TNM spent an annual average of MK13, 945, 454.50, MK10, 409, 090.90 on advertising and promotions respectively. The table also shows that TNM generated an annual average amount of MK 683 292 727.30 as sales volume. In addition, it can be observed from Table 2 that the standard deviation for promotion is relatively smaller as compared to that of advertising and sales volume suggesting that the latter variables are multimodal.

Table 2 also shows skewness and kurtosis both of which have an associated standard error. So, converting them to z-score by dividing them by their standard errors gives (i) for advertising cost: Z-skewness = 0.9758, and Z-kurtosis = -0.4081; (ii) For Promotion Cost: Z-skewness = 0.9062, and Z-kurtosis = 0.1196; and (iii) for Sales Volume: Z-skewness = -0.0908, and Z-kurtosis = -0.699.

The positive z-skewness for advertising indicates that the expenditure are positively skewed showing a pile-up of expenditure to the left of the distribution while the negative value of the z-kurtosis for advertising indicates almost a flat distribution of the data. Likewise, promotion cost data shows that data was piled-up to the left with at least a flat distribution. However, sales volume statistics reveal that the data was piled-up to the right and was pointy. The reported partial correlation coefficients (from Table 3, 0.936, 0.950, and 0.966.) indicate a very strong and positive correlation among the sales volume, advertising cost, and cost of promotions in that order. This is achieved at a significant p-value that is close enough to zero.

Normality test (see Table 4) of data gives Kolmogorov-Smirnov statistics for advertising cost, promotion cost, and sales volume as 0.214, 0.110, and 0.194 respectively; while Shapiro-Wilk statistics for advertising cost, promotion cost, and sales volume are 0.933, 0.972, and 0.873, respectively. Their corresponding p-values are greater than the significance level of 5% (>0.05). This indicates that the distribution of the sample is not significantly different from a normal distribution (i.e. it is in fact normal).

**Table 2 Descriptive statistics**

			Statistic	Std. Error
Advertising Cost	Mean		13945454.5455	1136930.76757
	95% Confidence Interval for Mean	Lower Bound	11412214.9302	
		Upper Bound	16478694.1607	
	Skewness		.645	.661
	Kurtosis		-.522	1.279
Promotion Cost	Mean		10409090.9091	1132852.75826
	95% Confidence Interval for Mean	Lower Bound	7884937.6648	
		Upper Bound	12933244.1534	
	Std. Deviation		3757247.54187	
	Skewness		.599	.661
Kurtosis		.153	1.279	
Amount of sales Volume	Mean		683292727.2727	78772951.62324
	95% Confidence Interval for Mean	Lower Bound	507775653.2753	
		Upper Bound	858809801.2701	
	Std. Deviation		261260324.16312	
	Skewness		-.060	.661
Kurtosis		-1.894	1.279	



**Table 3 Partial correlations**

		Sales Volume	Advertising cost	Promotion cost
Pearson Correlation	Sales Volume	1.000	.936	.950
	Advertising cost	.936	1.000	.966
	Promotion cost	.950	.966	1.000
Sig. (1-tailed)	Sales Volume	.	.000	.000
	Advertising cost	.000	.	.000
	Promotion cost	.000	.000	.

**Table 4 Normality test**

	Kolmogorov-Smirnov			Shapiro-Wilk		
	Statistic	df	Sig.	Statistic	df	Sig.
Advertising Cost	.214	11	.169	.933	11	.442
Promotion Cost	.110	11	.200(*)	.972	11	.904
Amount of sales Volume	.194	11	.200(*)	.873	11	.085

### 3.1 Parameter estimates

Two models were developed as shown in Table 5. The first was a simple linear regression model with only advertising cost as an independent variable and  $R = 0.876$ . The second model included two predictor variables, advertising cost and promotion cost which increased  $R$  to  $0.907$ . Not only did the second model improve on  $R$ , but rather it also improved the adjusted  $R$  from  $0.855$  to  $0.870$  producing an observed difference between  $R$  and adj.  $R$  (shrinkage) of  $3.7\%$ . Thus the inclusion of promotion cost to model 1 results into model 2, which is observed to explain larger variations in the sales volume than model 1.

The  $F$  statistics for testing the significance of model 1 and model 2 in predicting sales volume. For model 1;  $F = 42.232$ ,  $df = 6$  and  $p = 0.001$  and for model 2;  $F = 1.722$ ,  $df = 5$  and  $p = 0.246$ . This indicates that model 1 is not significant while model 2 is significant at the level of .

The Durbin-Watson in Table 5,  $d = 1.19$ , indicates that the error terms are random and hence they are not autocorrelated. There is no cause to worry about autocorrelation.

Table 6 shows the estimated coefficients for model (2). The first part of the model gives the estimates for the beta-values, which indicate the individual contribution of each predictor variable to the model. Thus model (2) can be used to estimate sales volume as follows:

$$\hat{y} = -2.74(10^8) + 25.618x_1 + 61.751x_2$$

$$Se(\beta_0; \beta_1; \beta_2) = (2.33E+08); (49.414); (47.062) \text{ respectively.}$$

Where the variables are as defined in model (1).

The parameters in model (3) are seen to be significant from Table 6 since for model 2 with  $p = 0.292 > 0.05$ ; with  $p = 0.626$ ; and with  $p = 0.246$ .

**Table 5 Model of Summary**

Model	R	R Square	Adjusted R Square	Std. Error of the Estimate	Change Statistics				Durbin-Watson	
					R Square Change	F Change	df 1	df 2		Sig. F Change
1	.936 <sup>a</sup>	.876	.855	81115684	.876	42.237	1	6	.001	
2	.953 <sup>b</sup>	.907	.870	76637684	.032	1.722	1	5	.246	1.19

a. Predictors: (Constant), Advertising cost  
 b. Predictors: (Constant), Advertising cost, Promotion cost  
 c. Dependent Variable: Sales Volume

**Table 6 Model coefficients**

Model		Unstandardized Coefficients		Standardized Coefficients		95% Confidence Interval for B		
		B	Std. Error	Beta	t	Sig.	Lower Bound	Upper Bound
1	(Constant)	-4.99E+08	1.67E+08		2.981	.025	9.1E+08	8.9E+07
	Advertising cost	88.232	13.576		6.499	.001	55.012	121.452
2	(Constant)	-2.74E+08	2.33E+08		1.178	.292	8.7E+08	3.2E+08
	Advertising cost	25.618	49.414	.272	0.518	.626	101.404	152.64
	Promotion cost	61.751	47.062	.688	1.312	.246	-59.226	182.729

Dependent variable: Sales Volume

**Table 7 Correlations and collinearity statistics**

Model		Correlations			Collinearity Statistics	
		Zero-order	Partial	Part	Tolerance	VIF
1	(Constant)					
	Advertising cost	0.936	0.936	0.936	1.0	1.000
2	(Constant)					
	Advertising cost	0.936	0.226	0.071	0.067	14.841
	Promotion cost	0.950	0.506	0.178	0.067	14.841

The presence of multicollinearity in the fitted model was assessed by looking at the tolerance and VIF values. Table 7 indicates some presence of multicollinearity between advertising cost and promotion cost. How well could TNM's sales volume be predicted if data on advertising cost and promotion cost are given? This was answered by Theil U statistics in model validation. The calculated U statistics,  $U = 0.1002 < 1$ , indicates that the prediction model (3) is better approach in predicting sales volume.

**4.0 Conclusions and Recommendations**

With the emergence of mobile phone companies in Malawi, the model developed in this paper is valuable as it assesses the impacts of promotions and adverts on sales volume of a profit making company in Malawi. Though difficult to assess the company's performance by looking at sales volume as being explained by promotions and advertisements, this study has tried to postulate the impact of the two variables to the exogenous variable. Sales

volume is also explained by other variables, which in this study have been treated as control variables with the aim of measuring the influence of the two explanatory variables. It is hoped that the model would be useful in predicting sales volume by using amount spent on advertising and promotions.

Decision making at Telecom Networks Malawi Ltd concerns the whole company and its subsidiaries. The usefulness of this sales volume model developed in this paper largely depends on the services that TNM provides on the local market. If the central objective is to get the sales volume supremum, it is recommended that this model should be used directly by the management in investing the company's decisions when making budget.

The specific parameters estimated in the sales volume model in this study are applicable to Telecom Networks Malawi Ltd. The use of this model to other companies should be done upon proper verifications on data compatibility and the theorems used. Otherwise it is proper to carry out another study to suit that company's data. For further development of the model, it is recommended that the model should incorporate more variables including competitors, pricing system, number of employees and their salaries, and location whether urban or rural, among others. This would help to investigate if the resulting model would be optimal.

## References

1. Armstrong, J.S. 1970. An application of Econometric models to international marketing. *Journal of marketing research*, pp 190 – 198.
2. DelVecchio D., Henard D.H., and Freling T.H. 2006. The effect of sales promotion on post-promotion brand preference: A meta-analysis. *Journal of Retailing* 82(3), pp.203-213.
3. DelVecchio D., Henard D.H., and Freling T.H. 2006. The effect of sales promotion on post-promotion brand preference: A meta-analysis. *Journal of Retailing* 82(3), pp.203-213.
4. Greene, W.H. 2003. *Econometric Analysis*, 5th Ed. Pearson Educational International, New York University.
5. Jordan, E. 2008. Marketing Mix Modeling. *Analytic Partners Journal* [online], viewed 8 Sept, 2011, <<http://www.analyticpartners.com/services/marketing-mix-modeling/understanding.aspx> >
6. Miles, J. & Shavlin, M. 2001. *Applying regression and correlation: a guide for student and researchers*, Sage, London.
7. MIPA. 2008. Malawi Investment Promotions Agency. Business operating costs. Viewed 8 Nov, 2010 <<http://www.malawi-invest.net/index.html>>
8. Parsons L.J. 2004. An Econometric Analysis of Advertising, Retail Availability, and Sales of a New Brand. *Management Science Application Series* 20(6), pp.938-947.
9. Persaran, Hashem M., Simon M. Potter. 1992. Nonlinear Dynamics and Econometrics: An Introduction. *Journal of Applied Econometrics* 7(Supplement), pp.S1-S7.
10. Schuler, A.T. & Wallin, W.B. 1983. A Revised Econometric model of the domestic pallet market, Northeastern Forest Station. US Department of Agriculture, USA.
11. Tice, D. 2008. Knowledge Networks. Viewed 10 November 2010 <<http://www.knowledgenetworks.com/approaches/index.html>>

# INVESTIGATING THE PROCESS EFFICIENCY OF FLEXIGESTER AS AN ON-SITE ANAEROBIC FAECAL SLUDGE SANITATION SYSTEM FOR APPLICATION IN EMERGENCY SITUATIONS

Flavius Kamwani<sup>a</sup>, Bernard Thole<sup>a</sup>, Katie Anderson<sup>b</sup>, Grover H. Mamani Casilla<sup>b</sup>, Jan Spit<sup>b</sup>, Angus Gaisford<sup>c</sup>

<sup>a</sup> Department of Physics and Biochemical Sciences, University of Malawi, The Polytechnic, Chichiri, Blantyre 3; E-Mail: kamwaniflavius@yahoo.com; bthole@poly.ac.mw;

<sup>b</sup> WASTE Urban Sanitation Advisors, Nieuwehaven 201, 2801 CW Gouda, The Netherlands; E-Mail: catherine.anderson85@gmail.com; groverhmc@gmail.com; gmamani@waste.nl; jspit@waste.nl

<sup>c</sup> Manager, AquaidLifeLine orphanage village, Lunzu, Blantyre, Malawi. E-Mail: alg@Africa-Online.net

## Abstract

Worldwide, including in Malawi, there is an increase in natural disasters requiring emergency response. During an emergency faecal sludge management gets disrupted especially when the soils are unstable and the water table is high. In such situations there is need for emergency sanitation systems, such as a Flexigester. The Flexigester was piloted at AquaidLifeLine orphanage (Latitude 15.62285oS, Longitude 35.055672oE) in Blantyre, aiming at assessing its functionality, applicability and process efficiency regarding stabilisation, sanitisation and useful by-product generation. pH, Temperature, Chemical Oxygen Demand (COD) were monitored for stabilisation, Total Ammonia Nitrogen (TAN) and biogas collection for useful by-product generation and E. Coli and Total Coliforms for sanitisation. Using randomly selected days of May to December, 2014 and maintaining the system's 38 days faecal sludge retention time, grab samples were taken from three strategically chosen sampling points namely; feed point, digestate point and Pasteurisation point. The results showed that sanitisation succeeded in summer when temperatures were 34.39, 48.58 and 44.10 oC and not in winter when temperatures were 22.35, 36.79 and 33.24 oC for the feed, digestate, and pasteurised respectively with observed CFU/100ml in winter being greater than WHO guideline of 103 CFU/100ml. On the contrary, the system failed to stabilise effluent, the (COD) values (132.958, 134.337 and 110.077 mg/l in winter and 268.018, 423.982 and 278.191 mg/l in summer) being higher than the Malawi Standard guideline of 60mg/l. pH values remained within limits of 7.1-7.4 and TAN was between 25 and 30 mg/l. The flexigester harvested 1.5 m<sup>3</sup> and 5m<sup>3</sup> per day of biogas in winter and summer respectively against the designed 10m<sup>3</sup> per day. Generally, the Flexigester can work successfully in countries with tropical climates, since during summer, quality of final product was appropriate for direct handling and re-use and the treated product had a high concentration of nutrients making it a useful product for agriculture. However during winter a post-treatment is required to reduce the pathogen concentration. The Flexigester, as an emergency on-site anaerobic sanitation system, if reworked, can be very effective in providing solutions to a series of challenges such as safe waste management, sustainable agriculture, and fuel generation.

Key Words: Flexigester, Feed, Digestate, Pasteurised, Faecal Sludge, Emergency

## 1.0 Introduction

An emergency is a situation characterised by a clear and marked reduction in the abilities of people to sustain their normal living conditions, with resulting damage or risks to health, life and, livelihoods (Wisner & Adams, 2002a). Emergencies could be complex and over the past decades, the world has experienced an increase in both warfare, civil disturbance and large scale movement of people and natural disasters such as tropical storms, extreme heat/cold winds, floods, earthquakes, landslides and volcanic eruptions (Brown, Jeandron, Cavill, & Cumming, 2012, The Johns Hopkins and the International Federation of Red Cross and Red Crescent Societies, 2008, Malambo, 2014, Wisner et al., 2002a). Figure 1 below shows the trend of number of natural catastrophes worldwide 1980-2010.

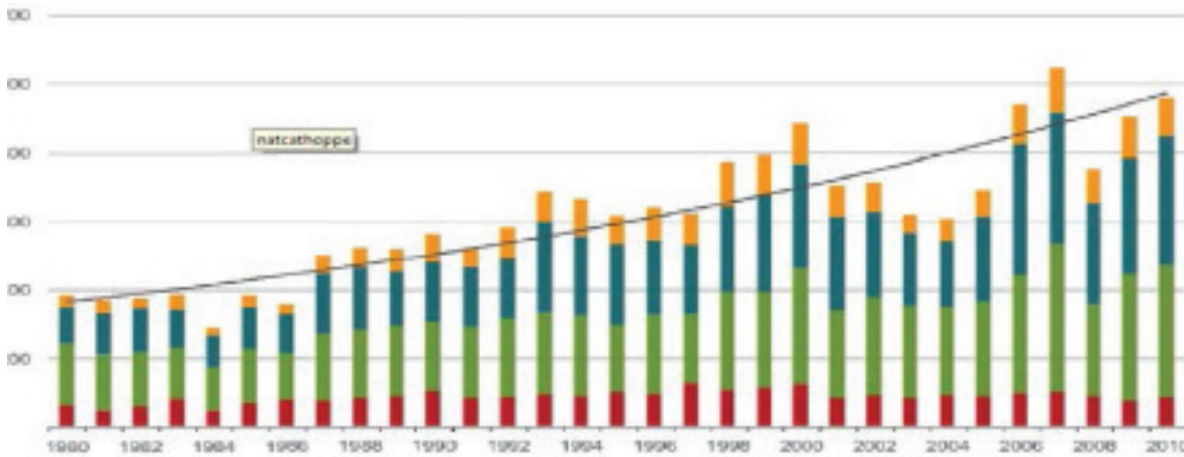

**Figure 1: Number of natural catastrophes worldwide 1980-2010, Source: Emergency Events Database (EM-DAT, 2011)**

For Malawi, most natural disasters arise from weather related events such as winds hailstorms and heavy rain, which results in floods. Amongst these events floods are the most occurring and have impacted Malawi more than 157 times since 1946 (Misomali, 2009). The districts which are most hit by floods include Nsanje, Chikwawa, and Phalombe (in the south), Salima and Nkhotakota (in the central region), and Karonga, Rumphu, and Nkhatabay (in the north).

For quite a long time, Malawi's response to natural disasters, just like the rest of the world, has put shelter and food as a priority at the expense of sanitary facilities (Misomali, 2009, Malambo, 2014, Spit, Malambo, Gonzalez, Nobela, Pooter, & Anderson, 2014). And yet a rapid influx of people in an emergency camp implies both an increased serious problem of produced waste water and sludge disposal. Sanitation becomes more challenging especially when there is flooding and the evacuation camps have unstable soils, high water tables and rocky soils (Wisner & Adams, 2002b, Brown et al., 2012). Looking at how challenging faecal sludge management could become emergency response organisations are obliged to implement sanitation technologies that will not only protect people, the environment and the natural resources but also, as mentioned by Esrey, Gough, Rapaport, Sawyer, Simpson-Hébert, Vargas, & Winblad, (1998) and cited by Kuffour, Awuah, Sarpong, Anyemedu, & Kone, (2013), allows for recycling of organic matter and nutrients.

It is worth mentioning that faecal sludge is a potential health hazard as it contains high numbers of cyst of protozoa, parasitic ova, and faecal pathogens like salmonella spp., shigella spp. and Escherichia Coli (Sinha, Herat, Bharambe, & Brahambhatt, 2009). And yet in emergency situations it is disposed of untreated at the shortest possible distance, on open ground, into drainage ditches, into water courses or onto the sea (Strauss, Larmie, & Heinss, 1997). Literature explains that Poor sanitation and hygiene practices leads to food contamination, outbreaks of faecal-oral related diseases such as diarrhoea, cholera and typhoid (Wisner et al., 2002b, International Federation of Red Cross and Red Crescent Societies, 2010, The Johns Hopkins and the International Federation of Red Cross and Red Crescent Societies, 2008). Such disease outbreak cases have been order of the day in the above mentioned districts and even Haiti. According to Johannessen (2011), and Bastable, & Lamb, (2012), as cited in Brown et al., (2012) disease outbreak incidences in emergency camps have not only exposed the emergency response gap of not properly managing sanitation at an early stage of an emergency, but also changed the approach to emergency response by organisations. This new approach has led to an ongoing call of investigating low-key faecal sludge treatment technologies, such as a Flexigester, that could both be rapidly deployed and effectively work under challenging physical conditions mentioned above (Spit et al., 2014)

A Flexigester, a faecal sludge anaerobic treatment technology developed by Sustainable One World Technologies (SOWTech), UK, is a water tight Anaerobic Digestion (AD) system that harvests biogas while sanitising and stabilising faecal sludge through solar energy pasteurisation. By definition, AD is a psychrophilic, mesophilic and thermophilic biological decomposition and stabilisation of biodegradable waste in the absence of oxygen and results in stable sanitised material that can be applied to an agricultural land to improve the soil structure or nutrients (Bywater, 2010, Zhang, 2010). It involves a series of stages namely hydrolysis, acidogenesis, acetogenesis and methanogenesis (Bywater, 2010, Sansalone & Srinivasan, 2004, Michigan Department of Environmental Quality, n.d.).

The Flexigester has been preferred, as an emergency sanitation system, over other sanitation systems due to the following reasons; Firstly, it is water tight making it more suitable for disasters resulting from floods. Secondly, it uses AD when treating faecal sludge, a well-known process for energy production, nutrient management, waste

stabilisation, and pathogen reduction (Bywater, 2010). Finally it has four bags which collect biogas, a by-product which can be used for both lighting and cooking in the camps. However, despite having the above mentioned qualities it is unknown whether the Flexigester can successfully treat faecal sludge. Hence this paper seeks to investigate, for a period of two seasons (Winter and Summer - May 2014 to December 2014), the functionality and applicability a flexigester as an on-site faecal sludge treatment system during emergency situations by quantifying the process efficiency in terms of stabilisation, sanitization and useful by-product generation, determining the impact of weather, seasonal and environmental factors on system performance and devising the process conditions required for the on-site sanitation systems to achieve Malawi Standard guidelines.

## 2.0 Materials and Methods

The flexigester, while placed above the ground, was connected to a pour flush toilet, as shown figure 2 below, and was used by 400 orphans, despite being designed for 200 people, found at AquaidLifeLine orphanage village (GPS coordinates: Latitude 15.62285oS, Longitude 35.055672oE) in Blantyre, Malawi.



**Figure 2 : Flexigester connected to pour flush toilet**

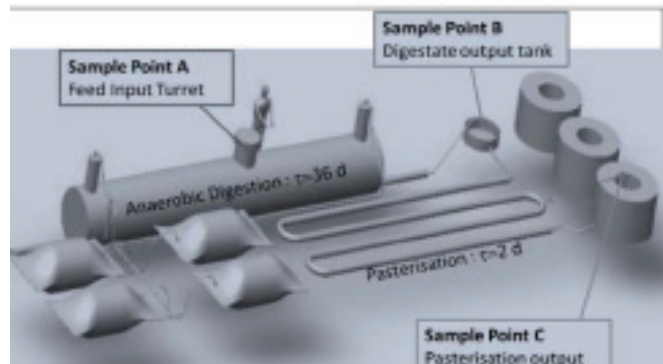

**Figure 3 : Flexigester connected to pour flush toilet**

To assess the Flexigester's sanitisation, stabilisation and capability of faecal sludge treatment the following parameters were analysed; pH, Temperature, Chemical Oxygen Demand (COD) Total Ammonia Nitrogen (TAN) and Pathogen reduction( E. Coli and Total Coliforms). The table 1 below shows the adopted American Public Health Association (APHA) specific methods for determining each parameter.

**Table 1: Analysed parameters with their methods**

No.	Parameter	Method
1	pH	Potentiometric SM-4500-H+
2	Temperature (°C)	SM-2550B
3	Escherichia coli	Pour plate SM-9020
4	Total Coliforms	Pour plate SM-9020
5	Total Ammonia Nitrogen (TAN)	Indophenol blue method Hach LR/HR TNTN tube test
6	Chemical Oxygen Demand (COD)	Hach tube test HR Oxidation by Potassium dichromate

Using the randomly selected days of the study period (May, 2014 to December, 2014), and while maintaining the system's 38 days faecal sludge retention time, 36 days for the digestion bag and 2 days for pasteurisation tubes, grab samples, in 1 litre sterilised sampling bottles, were taken from three strategically chosen sampling points, as indicated in Figure 3 above, and then transferred from the sampling site (Aquaid Lifeline) to Soche Pollution Control Laboratory for analysis. Parameters such as COD and TAN were analysed in triplicates while that of E. coli and Total Coliforms were analysed in duplicates with averages of both duplicates and triplicates analysed reported. Temperature and pH were measured in situ immediately after collecting the samples from the above mentioned sampling points.

Before the samples were taken, faecal sludge was mixed using a manually driven roller in order to ensure uniformity of the samples collected. Most of the analysis for E. coli were done within six hours from the time samples were taken and those that were not analysed within the six hours were refrigerated at 10oC till the next day. Due to flexigesre's failure to absorb enough solar energy, a plastic paper cover was created to raise the temperature. To enhance biogas production, 10% w/v of the cow dung was added to the flexigester. In addition

to the cow dung kitchen waste was put into the flexigester to boost up the concentration of carbohydrates, lipids and fats which are central to the anaerobic digestion stage called hydrolysis.

### 3.0 Results

A total of 24 samples, 13 in winter and 11 in summer, were analysed for COD, Temperature, pH, TAN, E. coli and Total Coliforms and table 2 below shows the results of the analysis.

**Table 2: Average Values for COD, Temperature pH, TAN, E. coli and Total Coliforms**

	Winter				Summer			
	N	Mean	Optimal Limit	Std. Deviation	N	Mean	Optimal Limit	Std. Deviation
	Statistic	Statistic		Statistic	Statistic	Statistic		Statistic
<b>Stabilisation</b>								
<b>COD (mg/l)</b>								
Feed	13	132.958	60	86.133	11	268.018	60	276.589
Digestate	13	134.337		57.654	11	423.982		239.076
Pasteurised	13	110.077		26.910	11	278.191		256.460
<b>Temperature(°c)</b>								
Feed	13	22.35	42 - 75	2.31395	11	34.39	42 - 75	2.74133
Digestate	13	36.79		7.01104	11	48.58		1.62654
Pasteurised	13	33.24		5.72532	11	44.10		2.09046
<b>pH</b>								
Feed	13	7.2146	6.5 - 9	.30934	11	7.1582	6.5 - 9	.07985
Digestate	13	7.2777		.45192	11	7.3018		.12327
Pasteurised	13	7.2792		.33315	11	7.3655		.08825
<b>Useful By-Product</b>								
<b>TAN (mg/l)</b>								
Feed	13	15.387		3.817	11	25.515		5.214
Digestate	13	15.738		2.527	11	24.970		4.708
Pasteurised	13	15.172		2.598	11	25.5766		5.114
<b>Biogas (M<sup>3</sup>/day)</b>		1.5	10			5	10	
<b>Pathogen Reduction</b>								
<b>E. coli (CFU/100ml)</b>								
Feed	13	3.04 x 10 <sup>6</sup>	<10 <sup>3</sup>		11	<10 <sup>3</sup>	<10 <sup>3</sup>	
Digestate	13	1.57 x 10 <sup>6</sup>			11	<10 <sup>3</sup>		
Pasteurised	13	7.96 x 10 <sup>5</sup>			11	<10 <sup>3</sup>		
<b>Total Coliforms (CFU/100ml)</b>								
Feed	13	5.60 x 10 <sup>6</sup>	<10 <sup>3</sup>		11	<10 <sup>3</sup>	<10 <sup>3</sup>	
Digestate	13	2.46 x 10 <sup>6</sup>			11	<10 <sup>3</sup>		
Pasteurised	13	9.76 x 10 <sup>5</sup>			11	<10 <sup>3</sup>		

### 4.0 Discussion

The Flexigster will only be deployed for use in emergency situations if it demonstrates that it can stabilise faecal sludge, generate useful by-products from faecal sludge and most importantly reduce pathogens that are found in human waste. The paragraphs below outline a detailed description of how effective the sanitation system has been.

#### 4.1. Stabilisation

In order to assess the Flexigester's process efficiency in terms of stabilisation, three parameters were analysed namely COD, Temperature and pH.

##### 4.1.1 Chemical Oxygen Demand (COD)

Mean COD values in summer were 11/2 times more than their counterparts in winter (see table 2 above) with COD values for the digestate indicating a stronger positive linear relationship ( $r = 0.512$ ) than those of both feed ( $r = 0.338$ ) and pasteurised ( $r = 0.235$ ) such that 26.2% of the digestate's COD values, unlike 15% and 5% of both the feed and pasteurised respectively, are being explained by temperature. COD values for the digestate were generally higher as compared to those of feed and pasteurised. The higher digestate's COD could be due to the following reasons; firstly, because the digestate samples had more suspended solids (physically observed biodegradable organic compounds) than those of feed and pasteurised. This observation is strange since the Flexigester, being anaerobic digestion in nature should have had a steady sludge volume reduction (Wong & Law-Flood, 2011). This means that the system did not successfully wash out the suspended solids. Secondly, if the digestate had suspended solids in it, more than the feed, it could mean that the overloading of the system that took place, system was used by an average of 400 orphans against the designed 200, led to the sludge being washed out in the digestate by the high inlet flowrate/hydraulic load.

**Figure 4: Graph of COD against Time**

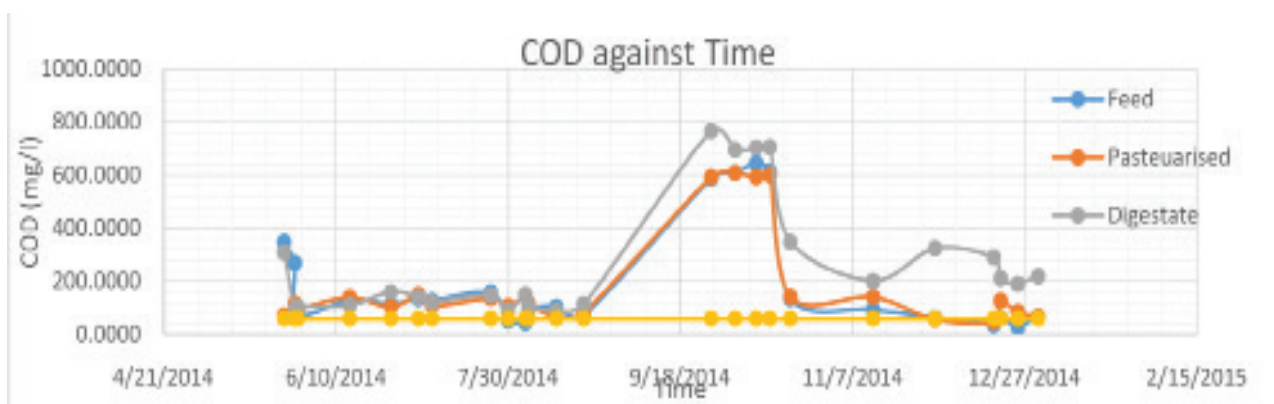

The graphical representation of COD values showed that COD for the feed, digestate and pasteurised went extremely high as the system was switching from winter season to summer. The higher COD values in September could be the result of the Flexigester's response to the temperature changes, from mesophilic to thermophilic ranges, because COD values went down again in early November. This COD sharp rise was expected because a rise in wastewater temperatures demands more oxygen for nitrification process (Atta, 2011). Overall the Flexigester's COD hardly went below the Malawi Standard guideline of 60mg/l which means that the faecal sludge was being discharged unstabilised.

##### 4.1.2 Temperature

During winter, the pasteurisation tubes were covered by a niche so that the temperature could be raised. However, despite covering the pasteurisation tubes, the raised temperatures were not able to meet the required thermophilic temperatures during this winter season. It is interesting to note that mean temperature values for the digestate were significantly higher than those of the feed and pasteurised in both seasons. This is regardless of being mesophilic (22.35, 36.79, and 33.24 °C for the feed, digestate, and pasteurised respectively) in winter and thermophilic (48.58, 44.10 °C), except feed (34.39 °C), in summer as can be seen in table 1 below. There was much variations in temperatures recorded during winter (25 – 42 °C) as compared to those recorded during summer (42–48 °C). The temperatures in winter were within mesophilic range (20–42 °C) (Metcalf & Eddy, 1995) as cited by Kuffour et al., (2013) while those in summer were within thermophilic ranges (42–75 °C) (Lettinga, 1995, Rajeshwari, Balakrishnan, Kansal, KusumLata, & Kishore, 1999). These variation actually explain the poor pathogen reductions explained in the paragraphs below as AD largely depends on operating conditions like temperature, PH, loading rate and influent strength because of the sensitivity of the methane producing bacteria (Rajeshwari et al., 1999)

##### 4.1.3 pH

There were no significant changes for the mean pH values for both winter (7.22, 7.28, & 7.28) and summer (7.16, 7.30, & 7.37) for the feed, digestate and pasteurised faecal sludge respectively. The pH range recorded for the entire study period were within optimal ranges (6.5–9) required by microorganisms to biologically degrade the organic matter (Veenstra & Polprasert, 1997) as cited by Kuffour et al., (2013), Rajeshwari et al., 1999, Strauss,



Larmie, Heinss, &Montangero, n.d.).This suggests that the Flexigster perfumed well in as far pH stabilisation is concerned. However there was weak positive linear relationship ( $r = 0.0617$  and  $0.088$ ) between pH values and temperature over the observed data with only 0.4% and 0.8% of the pH values being explained by temperature (see table 3 below).

**Table 3: Regression Analysis for, COD, pH and TAN with Temperature as independent variable**

N=24	Feed	Digestate	Pasteurised
<b>Stabilisation</b>			
<b>COD</b>	R <sup>2</sup> 0.150	R <sup>2</sup> 0.262	R <sup>2</sup> 0.055
<b>COD Linear Equation</b>	y = 0.388x - 140.02	y = 0.512x -32.08	y =0.235x - 6.29
<b>Useful By-products</b>			
<b>pH</b>	R <sup>2</sup> 0.035	R <sup>2</sup> 0.004	R <sup>2</sup> 0.008
<b>pH Linear Equation</b>	Y = -0.187x + 7.372	Y = 0.0617x + 0.179	y = 0.088 +7.199
<b>TAN</b>	R <sup>2</sup> 0.510	R <sup>2</sup> 0.398	R <sup>2</sup> 0.427
<b>TAN Linear Equation</b>	y = 0.714x -0.409	y= 0.631x.+0.082	y = .653x - 3.290

## 4.2. Useful By-Products

### 4.2.1 Total Ammonia Nitrogen

TAN observed data shows that the Flexigester is capable, just like any other functioning AD, of recovering useful by-products. TAN mean values in winter were approximately 40% lower than those in summer, regardless of the different sampling points (see Table 2). The recorded summer TAN concentrations have similar value trends (25-30mg/l) to what Siegrist, (1997) as cited by Montangero&Strauss, (2002) found while inhibiting methane-forming bacteria in digesters treating wastewater treatment plant sludge. However, TAN values, despite falling within optimal range, kept on increasing throughout the study period probably due to their being temperature dependent. The increasing trend explains why, regardless of the sampling point, the mean TAN obtained in summer were relatively higher than those obtained in winter. Unlike PH and COD values, TAN indicated a strong positive linear relationship (see table 3 above) at all sampling points with changes in temperature at all sampling points ( $r = 0.714$ ,  $0.631$ , and  $0.653$ ) with 51%, 39.8% and 42.7% of TAN for the feed, digestate and pasteurised respectively being explained by temperature.

### 4.2.2 Methane Gas

In order to assess Flexigester's capability of recovering useful by-products, four biogas collecting bags, were connected to the system. Three out of the four connected bags, filled with biogas, are shown in Figure 5 below and figure 6 shows a stick being burnt by the methane from one of the bags. The fact that methane was successfully harvested from the Flexigester and could ably burn shows that it is a good sanitation system especially during emergency situations because the harvested biogas could be used for both lighting and cooking. By design it was anticipated that the flexigester would harvest 10m<sup>3</sup> of biogas per day. However only half of the anticipated volume was been observed so far. This suggests that the COD is not currently being converted to methane (CH<sub>4</sub>) and from the data collected so far it is only 17% of the COD that is being removed. The low methane gas production further suggests that there is need for improving the AD as this could further reduce COD and increase CH<sub>4</sub> generation.

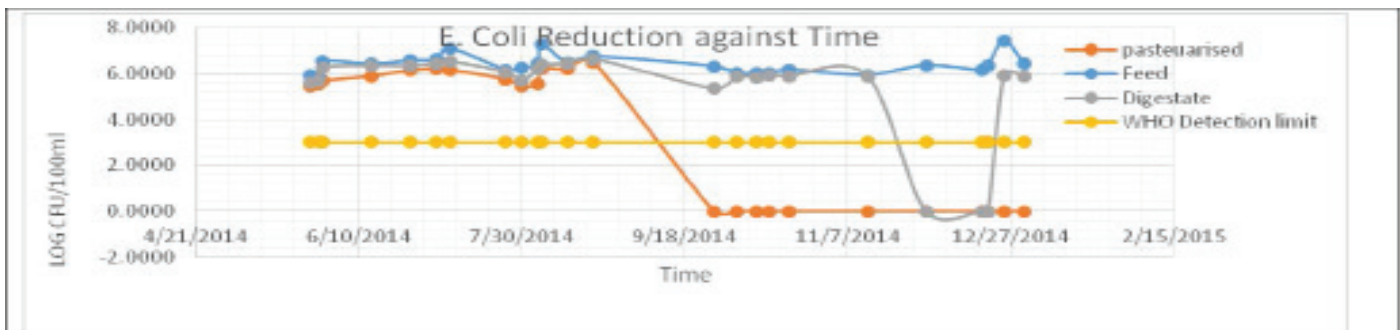

**Figure 5: Filled Biogas Bags**

**Figure 6: Methane Burning a Stick**

**4.3 Sanitisation/Pathogen Reduction**

Results evidently revealed that flexigester failed to remove or completely eliminate the pathogens from the pasteurized sludge in winter but significantly reduced them during summer (see Table 2 and Figures 7&8) despite its capability of harvesting biogas. This could be attributed to the system’s failure to absorb enough energy from the sun in order to meet the required thermophilic temperature range. The fact that standard pathogen reduction was not achieved during winter suggests maintaining thermophilic temperatures is very crucial for sanitisation to be met. Unlike the rest of the observed study period, the digestate indicates that it achieved Malawi Standard pathogen reduction guideline from mid November, 2014 to late December, 2014 probably due to either reduced number of people using the toilet or due to longer faecal sludge retention times as during this period the school’s orphanage had closed for Christmas Holiday.



**Figure 7: Graph of E. coli reduction against Time**

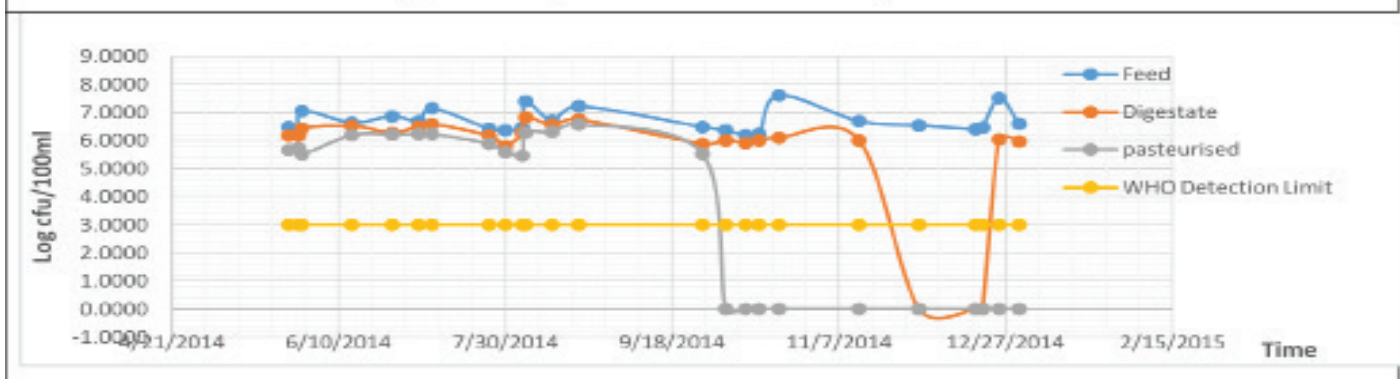

**Figure 8: Graph of Total Coliforms reduction against Time**

**5.0 Conclusion**

Generally, the Flexigester can work successfully in countries with tropical climate. The results indicate that during summer quality of the final product was appropriate for direct handling and re-use. The treated product had a high concentration of nutrients rendering it useful for agriculture. However, during winter either a post-treatment or an extension of sludge retention time is required to reduce the pathogen concentration. Overall, the Flexigester, as an emergency on-site anaerobic sanitation system, if reworked, can be effective in providing solutions to a series

of challenges such as safe waste management, sustainable agriculture, and fuel generation.

### 6.0 Recommendations

In order for the flexigester to ably meet the pathogen reduction standards, stabilise faecal sludge, generate useful by-products and its performance be consistent regardless of variations, seasonal and environmental changes, it is necessary to;

raise temperatures which could employ the biogas collected despite the mesophilic temperatures observed. The biogas could be employed to generate steam by boiling water which in turn could be used to heat the pasteurisation tubes to make the faecal sludge reach thermophilic temperatures. This could make the treatment process effective. It is proposed that this may be modelled from the design of a distillation process' condensing tube where there will be no direct contact between the faecal sludge and steam. This would enable the flexigester to be deployed to emergency sites that have mesophilic temperatures as the ones observed between May, 2014 and August 2014. Alternatively, the pasteurisation tubes could be modified by having stainless steel pipes at strategically placed points, where the burning biogas could be used to heat the pipes thereby raising the temperatures so that pasteurisation of faecal sludge gets achieved.

increase faecal sludge retention time by putting retention bags at the end of the pasteurisation tubes. The retention bags could act as faecal sludge maturation ponds before the actual disposal into the donuts because treating faecal sludge using maturation ponds has proven successful in many cities. Further modifications could be construction of drying beds at the end of pasteurisation tubes. The faecal sludge discharged in these drying beds could further be treated using lime or urea, one of the off-site faecal sludge treatment options.

join the flexigester system to a constructed wetland to help in disposing the effluent into a scientifically proven waste water treatment system. As mentioned above, the flexigester has failed to meet the 10m<sup>3</sup> biogas production target. Further research could be carried in order to establish the right loading rates that could produce the designed 10m<sup>3</sup> biogas volume per day. It is worth mentioning that the designed 10m<sup>3</sup> is achievable as there is a lot of existing evidence that AD registers high energy recovery

vermicomposting the flexigester's effluent in order to enhance nutrient concentration and reduce the pathogen concentration. According to literature biogas from AD systems is a mixture of methane, Carbon dioxide, and hydrogen sulphide among other components. Amongst these gasses methane constitutes approximately 50 - 75%. However, despite the flexigester producing biogas it is not known what percentage of the gas is methane and this could be another area of further studies.

### 7.0 Acknowledgement

The authors would like to thank the Polytechnic, a constituent college of the University of Malawi, the entire staff at AquaidLifeLine orphanage village, Blantyre, Malawi for the support rendered throughout the study period, and WASTE and International Federation of Red Cross (IFRC) for providing the resources for the research.

### 8.0 References.

1. Atta, A.M., (2011). Nitrogen Reduction in Wastewater Treatment in Egypt. *BordnaMóna Environmental Products U.S.* pp.5. Retrieved from [http://www.academia.edu/7719624/Nitrogen\\_Reduction\\_in\\_Wastewater\\_treatment\\_in\\_Egypt](http://www.academia.edu/7719624/Nitrogen_Reduction_in_Wastewater_treatment_in_Egypt) Accessed: 2015-04-18
2. Bastable, A., Lamb, J., (2012). Innovative designs and approaches in sanitation for challenging and complex humanitarian urban contexts *Waterlines* 31(1)
3. Brown, J., Jeandron, A., Cavill, S., & Cumming, O., (2012). Evidence review and research priorities: Water, sanitation, and hygiene for emergency response. London School of Hygiene and Tropical Medicine (LSHTM). Sanitation and Hygiene Applied Research for Equity (share). Retrieved from [http://r4d.dfid.gov.uk/pdf/outputs/sanitation/Evidence\\_review\\_\\_WASH\\_for\\_emergency\\_response\\_March\\_2012.pdf](http://r4d.dfid.gov.uk/pdf/outputs/sanitation/Evidence_review__WASH_for_emergency_response_March_2012.pdf) Accessed on 2014-12-22
4. Bywater, A., (2010). A Review of Anaerobic Digestion Plants on UK Farms - Barriers, Benefits and Case Studies. (pp. vii, 4), Stoneleigh Park, Warwickshire, CV8 2LZ. England. Royal Agricultural Society of England. Retrieved from <http://www.fre-energy.co.uk/pdf/RASE-On-Farm-AD-Review.pdf> Accessed on 2014-01-11
5. Emergency Events Database (EM-DAT, 2011) Retrieved from <https://makewealthhistory.files.wordpress.com/2011/05/disasters-munichre.jpg>
6. Esrey, S.A., Gough, J, G., J., Rapaport, D, R., D., Sawyer, T, S., T., Simpson-Hébert, M, S.-H., M., Vargas, J., V., J..., Winblad, U., W., U., (1998). Ecological Sanitation. SIDA, Swedish International Development Cooperation Agency, Stockholm
7. Havelaar, A., Blumenthal, U.J., Strauss, M., Kay, D., Bartram, J., (2001). Guidelines: the current position, in: *Water Quality: Guidelines, Standards and Health*. IWA Publishing, pp. 17 – 42. ISBN: 924154533X (WHO), 1900222280 (IWA Publishing) Retrieved from [http://www.who.int/water\\_sanitation\\_health/dwq/whoiwa/en/](http://www.who.int/water_sanitation_health/dwq/whoiwa/en/) Accessed on 2015-04-18

8. International Federation of Red Cross and Red Crescent Societies, (2010). Annual Report 2010 (Annual Report). CH-1211 Geneva 19, Switzerland. International Federation of Red Cross and Red Crescent Societies. Retrieved from <http://www.ifrcmedia.org/assets/pages/annual-report/resources/IFRC-Annual-report-2010-English.pdf> Accessed on 2014-05-12
9. Johannessen, A, (2011). Identifying gaps in emergency sanitation: design of new kits to increase effectiveness in emergencies. (pp. 22–23) Stoutenburg, Netherlands: Oxfam WASTE
10. Kuffour, A.R., Awuah, E., Sarpong, D., Anyemedu, F.O.K., Kone, D., (2013). Effects of Different Solid Loading Rates of Faecal Sludge on the Dewatering Performance of Unplanted Filter Bed. *Civil and Environmental Research* 3(4), 39–48. ISSN: 2224-5790 (Paper), 2225-0514 (Online). Retrieved from <http://www.google.com/url?sa=t&rct=j&q=&esrc=s&source=web&cd=1&ved=0B0QFjAA&url=http%3A%2F%2Fwww.iiste.org%2FJournals%2Findex.php%2FCER%2Farticle%2Fdownload%2F5046%2F5145&ei=I5weVYudOsKwUbHgg7AJ&usg=AFQjCNF8zn1XnINNTyUrANGPwhSXLjVT-Q&sig2=0bp8vUxvcokiSXzJu3046w&bvm=bv.89-947451,d.d24> Accessed on 2014-10-14
11. Lettinga, G., (1995). Anaerobic digestion and wastewater treatment systems. *Antonie Van Leeuwenhoek* Volume: 67, 3–28. Retrieved from <http://link.springer.com/article/10.1007/BF00872193#page-1> Accessed: 2014-10-14
12. Malambo, D., (2014). Sanitising Faecal Sludge using Lactic Acid Bacteria in Emergency (MSc Thesis, UNESCO-IHE Institute for Water Education, Delft, The Netherlands). Retrieved from <http://emergencysanitationproject.wikispaces.com/file/view/MWI+SE+2014-21.Dennis+Hanjalika+Malambo.pdf> Accessed 2015-02-25
13. Metcalf, L., Eddy, H.P., (1995). *Wastewater Engineering-Treatment, Disposal and reuse*, (3rd Ed.). New York: McGraw-Hill.,
14. Michigan Department of Environmental Quality, (n.d.) Operator Training and Certification Unit, Anaerobic Sludge Digestion Process. Michigan. Retrieved from <https://www.google.com>

# Challenges and Opportunities in Using GIS for Monitoring and Management of HIV/AIDS: A Case Study from Malawi

*Brown Msiska<sup>a</sup> and Patrick Chikumba<sup>b</sup>*

<sup>a</sup> University of Malawi, Chancellor College, Department of Computer Sciences

<sup>b</sup> University of Malawi, The Polytechnic, Department of Computing and Information Technology

<sup>a</sup> bmsiska@gmail.com

<sup>b</sup> pchikumba@poly.ac.mw

\*Corresponding author: pchikumba@poly.ac.mw

## Abstract

This research falls within the domain of Health Information Systems (HIS) development with particular interest in developing countries. The main objective of the research was to study HIS in order to highlight challenges and opportunities in using Geographical Information System (GIS) for monitoring and management of HIV/AIDS in Malawi. The research studies were done at both the national level (National AIDS Commission and Ministry of Health) and district level (Zomba and Balaka).

Qualitative research methods were used which included interviews, document analysis and observations. A GIS prototype was constructed in order to facilitate understanding of practical issues surrounding the intended use of GIS.

The research revealed the presence of GIS technology within the Malawian health sector. However, its use has been limited to research with no specific evidence of its use in monitoring and management of HIV/AIDS. In order to understand existing challenges this research draws from the Information Infrastructure theory in terms of installed base, heterogeneity and standardization concepts. The research emphasizes on the need for local capacity for sustainability and scalability of GIS projects. Furthermore, in recognizing the need for cost-effectiveness of GIS projects in developing countries the research advocates for setting up infrastructure and building partnerships to facilitate sharing of spatial data between institutions.

**Keywords:** Health Information System, Geographic Information System, Information Infrastructure, Monitoring and Evaluation.

## 1.0 Introduction

HIV/AIDS is global health crisis that countries world wide are currently battling. Nowhere in the world is the crisis as severe as in the Sub Saharan Africa region. The Government of Malawi (GoM) has responded by mobilizing a multi-sectoral national response to the HIV/AIDS crisis by establishing the National AIDS Commission (NAC) to coordinate the national response. While progress has been made in HIV testing and counseling, provision of anti-retroviral (ART) treatment, prevention of mother to child transmission (PMCT) and other HIV/AIDS intervention programmes there is still a need to strengthen monitoring and evaluation. One way is by making use of Geographic Information Systems (GIS) (Hugo 2000; Vanmeulebrouk et al. 2008).

Health is largely determined by environmental factors which vary greatly in space; making the spatial dimension important in addressing health issues (Tanser & Sauer 2002). Thus, HIV/AIDS as a health issue has a spatial dimension that ought to be considered. Important questions like whether HIV/AIDS intervention programmes reach the populations in need cannot be adequately addressed without considering the spatial dimension. Furthermore, under resource constrained conditions the spatial dimension becomes very important when it comes to deployment of already scarce resources in order to ensure their effectiveness (Hugo, 2000).

However, Health Information Systems (HIS) in Africa have often overlooked the spatial dimension when dealing with the HIV/AIDS epidemic and other important health issues (Tanser & Sauer 2002). While it is possible to work without taking into account this geographical component; using spreadsheets or databases, for example, this is effectively throwing away potentially important and valuable information (Saugene 2005). This inadequacy resulting from failure to adequately address the spatial dimension means that decision makers are hampered from making well-informed and much directed decisions on preventative and intervention programmes. With the decision making process hampered in such a way, the success of preventative and intervention programmes is limited.

Although this is the case, GIS has been shown to have potential to assist in the fight against HIV/AIDS by

providing excellent means for presenting, visualizing and analyzing disease data (Hugo 2000). The spatial modeling capacity offered by GIS is directly applicable to understanding the spatial variation of the disease, and its relationship to environmental factors and the health care system (Tanser & Sauer, 2002). GIS projects in developing countries like Malawi face unique challenges mainly due to infrastructural and cost constraints (Hall et al. 1997; Dunn et al. 1997; Tanser & Sauer 2002). Thus, this research sought to explore GIS in Malawi in order to see how GIS can be used in the monitoring and management of HIV/AIDS and understand the challenges and opportunities that exist in that regard.

## 2.0 Literature Review

Epidemiology can be defined as the study of the distribution and determinants of health related states and events in populations, and the application of this study to control health problems (Balaji 2000). Inherent in this definition is the measurement of frequency, distributions and determinants of diseases (ibid). In order to understand, interpret and take action on any of these factors the spatial dimension is very important. The question of location (where?) is important to these three factors. Thus, GIS is seen to be well suited for application as a tool for monitoring and management of epidemics, a major concern of epidemiology.

GIS provides excellent means for visualizing and analyzing epidemiological data, revealing trends, dependencies and inter-relationships that would be more difficult to discover in tabular formats (Johnson and Johnson, 2001). Epidemiological analysis involves the study of relationships and dependencies between several factors and trends associated with a particular disease in order to allow predictive insights that can help monitor and control the disease. Such a task is difficult to undertake with traditional reporting systems that are characterized by presentation of data in tabular forms. Making sense of information across two or more tables can prove difficult, tedious, time consuming and slow. GIS with its excellent visualizing and analyzing abilities is therefore well suited to epidemiology as it is capable of strengthening the whole process of epidemiological information management and analysis.

HIV/AIDS, like tuberculosis and malaria, is an "environmental" disease (Tanser & Sauer, 2002). The distribution and incidence levels of such diseases are considerably dependent on environmental or spatial factors. It is for these so called "environmental" diseases that GIS is seen to be well-suited and highly applicable in terms of research, monitoring and management (ibid). Therefore, the potential of GIS is highly applicable in research, monitoring and management of HIV/AIDS. In providing treatment to those already infected with the disease the spatial dimension is very important when it comes to deployment of already scarce resources in order to ensure effectiveness (Hugo, 2000).

Modern GIS have the capacity to analyse huge amounts of spatially referenced information and present it in the form of maps extremely quickly (Hugo, 2000). With such speed information can be made available in good time to policy makers and planners in a form which allows patterns and trends to be readily identified. As a result action can be planned and taken immediately and as such enhance the chances of it being effective.

Furthermore, GIS allows overlaying of a number of layers of information (Johnson and Johnson, 2001). With respect to HIV/AIDS, the layers of information can include distributions of all the elements thought to influence the spread of the disease, such as locations of roads and health centres, migration patterns, incidence of prostitution, population density and drug use.

The simplest use of the visualisation capabilities of GIS is the production of maps of the incidence/prevalence of HIV/AIDS (Hugo, 2000), for example, of the distribution of HIV/AIDS in Malawi. In addition, GIS has the ability to 'zoom in' to very local or regional scales of visualization, for example district level. It is obvious that such maps can go a long way in assisting in planning interventions.

With GIS it is possible to have a map and a model that can be used to determine the optimal allocation of resources across different areas (Hugo, 2000). In the case of HIV/AIDS it could be used to decide where to locate counselling and testing services, condom distribution programs and so on.

Furthermore, GIS also enables evaluation of the effectiveness of services and resource allocations after they have been made (Hugo, 2000; Johnson & Johnson, 2001). If services and the allocation of resources are effective then they should reduce the extent of the disease, over time, in the areas where they have been deployed. GIS with its ability to show spatial distribution of diseases in space and time can assist in monitoring changes in the areas where such resources, services and intervention programmes have been deployed in the fight against HIV/AIDS.

Web GIS is a recent development that allows users to connect to a central GIS server through the internet or

intranet (Johnson and Johnson, 2001). This opens up GIS across the entire stakeholder community in the fight against HIV/AIDS allowing operatives in the field to access and manipulate data sets with respect to their planning and operational activities (Hugo, 2000). Furthermore, central decision making is better informed by local knowledge leading to better decisions (ibid).

Tanser & Sueur (2002) discovered that most research on HIV/AIDS in Africa concentrated more on temporal analysis than the spatial dimension. Recent studies do not indicate a major shift from that. There is little current research on HIV prevalence in Africa that has utilized GIS technology to its full potential (Montana et al, 2006). A majority of published studies on application of GIS in health-related issues are undertaken in South Africa. This raises questions on what is being done concerning the application of GIS in dealing with HIV/AIDS in other Sub Saharan Africa countries, including Malawi.

There have been questions raised on the appropriateness of GIS for poor developing countries. Can a technology initiated and concentrated in industrialized countries be valuable where fewer resources are available? (Dunn et. al., 1997). Developing countries face a myriad of challenges in GIS projects: cost of acquiring GIS technology, lack of local knowledge and expertise in GIS technology, availability of usable geo-referenced data (Hall et. al., 1997).

Despite these challenges Dunn et. al (1997) argue that GIS is still applicable in developing countries. It is important to realize that a lack of appreciation of potential of GIS exists in most developing countries. Simply providing a GIS solution does not help at all if the people to use it do not know how it helps them. Dunn et.al. (1997) and Hall et. al. (1997) argue for training and building of local capacity as one of the strategies for sustainable GIS projects in Africa and other developing countries.

Tanser (2000) argues against the issue of cost of GIS by observing that hardware has become increasingly cheaper and powerful. As a result of these trends, complex analysis of spatial data can be done with a desktop computer. At the same time while in the past decade GIS software was to a larger extent commercially available this decade has seen an increasing amount of free GIS software (ibid) which developing nations can take advantage of.

### **3.0 Methodology and Theoretical Framework**

In order to understand challenges and opportunities in the adoption of GIS for the monitoring and management of HIV/AIDS programmes there is a need to understand people and institutional behaviors and practices involved. All this makes the qualitative research approach an ideal option for this study. A case study approach was adopted to help explore HIS in Malawi with respect to the objectives of this research. At the national level, the study focused on the MoH and NAC who are the dominant bodies in the monitoring and management of HIV/AIDS programmes. At the district level, the District Health Office is key coordination point for HIV/AIDS programmes. In this study, two districts (Zomba & Balaka) were visited.

Data collection was predominantly conducted using interviews as the primary data collection technique which was supported by document review and to a lesser extent observation where possible. In addition to these, prototyping was also used to collect data of practical relevance and to gain a practical understanding of opportunities and challenges that exist with regard to the objectives of this study. To facilitate the data collection process an approval was sought from MoH and National Health Sciences Research Committee.

During data collection, analysis started with transcribing, expanding and organizing of data collected from field work into a memo. This was done immediately after the fieldwork – interviews, document analysis and so on – in order to ensure that important details were not forgotten. The outcome of this process was further analysed in order to draw meanings, inferences and identify gaps. Analytical notes were made from this analysis. Gaps needing further clarification were subsequently followed up by collecting more data thereby increasing the validity and the reliability of the data collected. This kind of analysis also provided background information which was crucial in the planning of subsequent data collection efforts.

The data analysis, done at this stage, mainly employed triangulation and content analysis techniques. By triangulating data sources and data collecting techniques inconsistent and contradictory data was identified and due clarification was sought where necessary. This enhanced the reliability and validity of the data collected. Further data analysis, after data collection, involved making use of the established conceptual framework to draw meaning, understanding and explanations to the research findings.

This study to a larger extent focused on the extension of existing HIS by adopting GIS technology. According to Hanseth (2002), any new or improved elements have to fit with the old. The installed base has some influencing and limiting powers which can help explain some challenges and opportunities encountered in the process.

GIS like most infrastructure has evolved and continues to evolve over time. GIS has been described as enabling technology readily applicable in the health sector (Tanser & Sueur, 2002). GIS applications are shared between individuals and often between organizations as well. GIS is open as it offers possibility of being linked to other information resources like relational databases and other IS. It can be seen that GIS is heterogeneous in terms of stakeholders, tools and other artefacts involved, procedures and so on.

**4.0 Mapping for Monitoring & Management of HIV/AIDS**

In the monitoring and management of HIV/AIDS, there are a good number of analysis that should be done in order to provide relevant information. The analysis can be on HIV/AIDS prevalence and its trends, service distribution, performance indicators for services, and resource allocation. Currently, information is provided mainly in the form of tables and charts, for example, as shown in Figure 1.

**Figure 1: Sample Table and Chart**

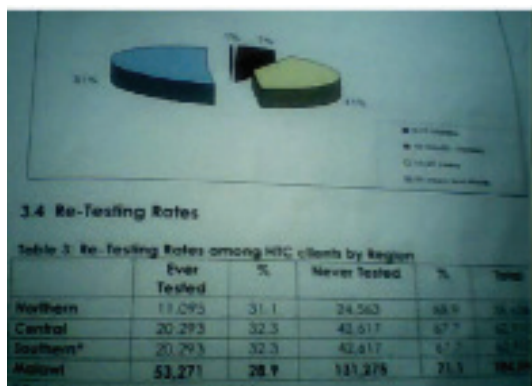

**4.1 Mapping HIV/AIDS Prevalence**

At the district level HIV/AIDS prevalence data was not readily available and estimates from the data collected during the 2007 HIV Testing and Counselling week were used instead. First, the HIV prevalence levels were classified (categorized) into three groups: high, medium and low. With that classification the prototype was able to map districts with high, medium or low HIV prevalence health zones as shown in Figure 2.

**Figure 2: Estimated HIV/AIDS Prevalence Levels for Zomba - 2007**



**4.2 Mapping HIV Prevalence Trends**

The ability to monitor HIV prevalence trends is crucial to monitoring and management of the epidemic in general. By looking at the trends managers can determine if intervention programmes are having the desired impact or not.



To map HIV prevalence trends there is a need to have prevalence data for at least two time periods. However, at the district level there was data for 2007 only. On the other hand, at the national level prevalence data according to regions was available for years 2001, 2003, 2005 and 2007. As the result the prototype could only map HIV prevalence trends for the national level. This was done using data for four years 2001, 2003, 2005 and 2007 (see Figure 3). The analysis shows The general trend is that HIV prevalence in Malawi has been decreasing with the exception of the period between 2003 and 2005.

**Figure 3: Regional HIV Prevalence Trends 2001 - 2007**

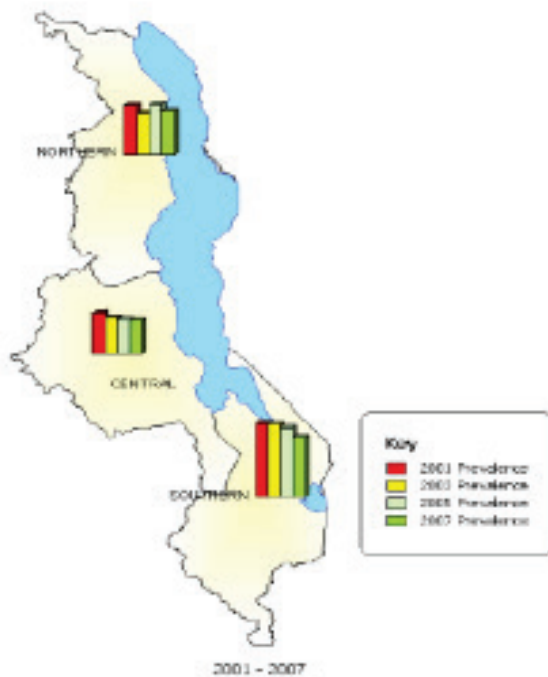

#### 4.3 Mapping HIV/AIDS Service Distribution

Another requirement the prototype was set out to meet was to map the distribution of HIV/AIDS services within a district. There are three main HIV/AIDS services ART, PMTCT and HTC. In the case of Zomba, HTC is provided by all health facilities. Having mapped the service distribution it is possible to visualize where services are offered and how accessible they are to certain communities (see Figure 4).

**Figure 4: Distribution of HIV/AIDS Services in Zomba**



#### 4.4 Mapping Performance Indicators for HIV/AIDS Services

For purposes of the prototype, HTC programme was chosen which has basically two main performance indicators: (a) testing and (b) results-delivery coverage (see Figure 5). The testing coverage is the percentage of the number of people expected to be tested in a period that have actually been tested. The results-delivery coverage is the percentage of people tested that actually receive their results.

**Figure 5a: Zomba HIV Testing Coverage 2007**

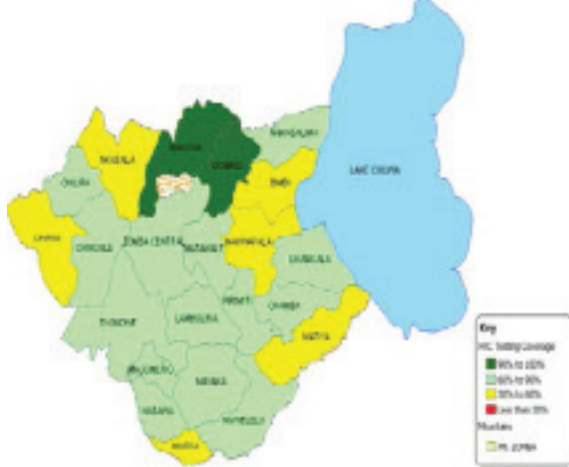

**Figure 5b: Zomba Results-Delivery Chart-Map 2007**

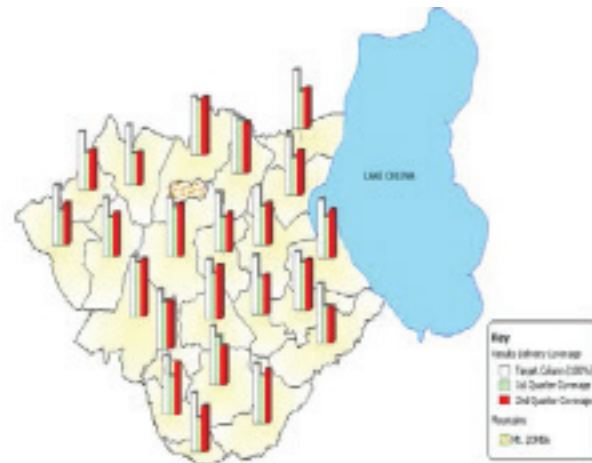

Furthermore, as Figure 5b shows, the prototype enabled comparison of performance indicator values between two or more periods. For example, 1st Quarter is being compared with 2nd Quarter result-delivery coverage for 2007 within health catchment areas. The target column parameter was introduced to circumvent a limitation in the charting feature in ArcGIS. It basically indicates where 100 % coverage would be.

**4.5 Mapping and Assessing Resource Allocation**

One aspect of management of HIV/AIDS involves managing resources which could be human resources, equipment, medical supplies and so on. Input indicators are used to measure the amount of resources required, allocated or used. One of the factors crucial to fair allocating resources is population. For purposes of the prototype an assessment of HTC counsellors allocation was made to see if they had been fairly distributed across the three regions.

Region	Population	Counsellors
Southern	5,876,784	1049
Central	5,491,034	612
Northern	1,698,502	429

The formula used was: 
$$Ec = \frac{Population}{\sum Population} \times \sum Counsellors$$

where Ec is expected number of counsellors. This formula was input into the GIS system to enable it compute Ec given populations and number of counsellors in each region (see Figure 6).

**Figure 6: Comparing Expected and Allocated Number of Counsellors**

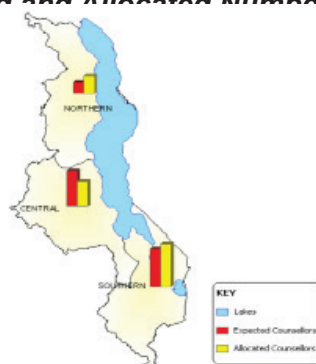

As shown, the number of allocated counsellors for the Southern and Northern Regions exceed their corresponding expected values where as in the central region the number of allocated counsellors is less than the expected number of counsellors.

While on face value (see Table 1) the Central Region seems to be better off in number of counsellors than the Northern Region, GIS system by factoring in population data shows that it is in fact the Northern Region which is better off. Thus, the GIS prototype allows valuation of resource allocation and vice versa.

### **5.0 Challenges in Using GIS for Monitoring and Management of HIV/AIDS**

One of the major challenges to adoption of GIS in developing countries has been a lack of local expertise (Hall et al. 1997). GIS implementation in developing countries has mostly been driven by international development agencies through contractually appointed expatriate employees (Taylor 1991 cited in Hall et al. 1997). Such it is the case with Malawi where GIS was introduced in MoH through a joint project with JICA with an expatriate consultant engaged in the process. While the project was successful in introducing GIS to the health sector the lack of local expertise has greatly affected the sustainability and the scalability of GIS usage. As at the time of this study MoH had only one statistician who was conversant with GIS. There is therefore limited GIS expertise at the Ministry's disposal which could be tapped into to support its routine use in various decision making processes of the Ministry, including monitoring and management of HIV/AIDS programmes.

On the other hand, pockets of GIS expertise are slowly emerging in the country through pursuits in the academic arena and departments in other ministries. Colleges and departments in the University of Malawi dealing with land surveying, geography and demography have GIS components in their courses. The National Statistical Office and the department of surveys are some other government bodies that have some on going activities with GIS. Nurturing these emerging pockets of GIS expertise could be the way forward to developing local GIS expertise.

Literature seems to agree that GIS is not a cheap venture (Hall et al. 1997; Van Loenen 2006; Vanmeulebrouk et al. 2008). Right from the acquisition of the software required, the licenses that go with it, required hardware like GPS units, the human resources with requisite skills and their maintenance, and getting spatial and non-spatial data, GIS can be an expensive venture. There are especially high costs associated with acquisition and maintenance of geographical data (Van Loenen 2006). For developing countries like Malawi the financial demands that go with the technology like GIS can easily become an impediment.

The sustainability of GIS applications initiated with aid from international development agencies has been put to question. Evidence suggests that once the projects come to an end and aid is withdrawn, so does the use of the technology as annual software maintenance fees cannot be paid and software upgrades fall increasingly behind current versions (Hall et al. 1997). Evidence from this study supports this observation. The ArcGIS version 3.1 being used in MoH is way behind the current version on the market.

Therefore, viable GIS applications in developing countries should deliberately incorporate cost-cutting measures. Shared geospatial infrastructures that reduce duplication of effort in the collection and storage of spatial data and use of open source alternatives to commercial GIS software are some of the ways that have potential to reduce the cost of GIS applications in developing countries (Van Loenen 2006; Vanmeulebrouk et al. 2008).

In an earlier discussion GIS has been shown as dependent on the installed base which includes spatial and non-spatial data. The availability and quality of both kinds of data can easily be an impediment to using GIS in the monitoring and management of HIV/AIDS programmes. The major constraint is the uniform absence of useable georeferenced and up-to-date data (Hall et al., 1997). While that might not be entirely the case with what this study found in Malawi, there are challenges with respect to both spatial and non-spatial data that ought to be considered and addressed if GIS is to be effectively used.

Data continuity is important to monitoring and evaluation as often data collected from two different periods have to be compared. The study, however, found cases where data continuity was not there, especially at the district level. Several reasons could be given for this. One is that data has historically been collected for the national level and once it has been submitted to that level it was not taken to be important anymore. The shift from this kind of data collection is as a result of the decentralization programme but traces of old centralized practices can still be found.

Without data continuity some of the potential uses of GIS in the monitoring and management of HIV/AIDS

programmes might not be feasible. For example, analysis of the prevalence trends of HIV/AIDS can be difficult without continuous availability of prevalence and incidence data.

As indicated earlier, the heterogeneity of stakeholders in the national AIDS response means that there are varied perceptions to data reporting obligations such that some implementers of intervention programmes are not well disposed towards submitting their activity data to NAC and the district AIDS coordinator. This creates gaps in the range of data available. Furthermore, there are delays in data submission by some implementers that further exacerbates the problem of data availability. In addition to this, community based organizations often have problems appreciating the importance of data, standards and quality and some do not go along with set standards for data collection and data reporting. This renders the data they submit either not useful or difficult to understand.

On the other hand spatial data mainly suffers from lack of updates. For example, the health geo-spatial register in MoH has rarely been updated since 2003. This means that any eventual use of the data there in does not take into account facilities that would have been put in place after 2003. While MoH has issued out GPS units to all districts updating the register has not started due to lack of training in their use and standards to follow in their use.

Diffusion in the application of GIS is directly related to the diffusion of knowledge in the potential contribution it can make to planning human service delivery in important areas, such as health (Hall et al. 1997). Awareness of technology and its potential benefits to a particular field is a driving factor in its adoption and diffusion. As people become aware of such benefits they are likely to demand for it in order to enhance and support corresponding activities. According to Hall et al. (1997) one of the issues at the core of problems encountered in Africa is a general low level of understanding of GIS concepts and spatial analysis and lack of appreciation of its potential applications in important areas that include health. As this study found out there is little of GIS and its possible applications in the health sector, especially at the district level. As stated earlier awareness of the benefits of a particular technology has in a particular field is a driving factor in its adoption. Thus, the slow diffusion of GIS in the Malawian health sector is partially due to a lack of awareness of its benefits by a majority of health personnel.

### **6.0 Opportunities in Using GIS for Monitoring and Management of HIV/AIDS**

NAC has a project currently underway whose aim is to put in place a GIS to be used for monitoring and evaluation (M&E) purposes. The system will tie up with the existing National M&E system. This project represents one of the major opportunities for using GIS in monitoring and management of HIV/AIDS in Malawi. They provide a learning platform where GIS potential benefits can be put to test and therefore contribute to creating an awareness that will help counteract the slow diffusion being associated with GIS within the health sector in Malawi. As people use IS to improve their processes they learn what is possible which helps them to become more confident in breaking out of the old mindset (Boddy et al. 2005). Thus, once the system being built is put to practice an increase in GIS knowledge can be expected which will help make other possible applications more apparent.

Procedures and regulations as part of the installed base can be a limiting factor in attempts to exploit GIS at different levels of implementation. In Malawi, certain HIV/AIDS statistics can only be computed and reported by NAC/MoH. However, depending on what GIS is to be used and the level at which it is being implemented, some practices might have to be reviewed in order to ensure the availability of required data. As people use IS they see new possibilities and are willing to abandon traditional ways of thinking which can block attempts at process change – which will require further new systems (Boddy et al., 2005). The use of the prospective GIS creates an opportunity to identify prohibitive procedures and regulations which when reviewed can help create a conducive environment for further adoption and diffusion of GIS.

Another plus towards the use of GIS in monitoring and management of HIV/AIDS is the existence of GIS technology at MoH, although its usage has been limited to research only. This works in favour of any subsequent projects to extend usage of GIS to other areas of applications. Such projects will not have to start from scratch but will benefit from the GIS traits of installed base resulting from current usage including the spatial data currently in use, established partnerships with other institutions as well as knowledge, experience and expertise in GIS.

Furthermore, this GIS existence creates room for experimentation with the technology which brings to light the potential benefits of its routine usage and also has potential to steer growth in knowledge and expertise on GIS which was found to be lacking. As argued by Boddy et al (2005), the use of technology or IS enables people to see other possibilities thus helping break old mindsets. It can thus be expected that through the use of already existing GIS knowledge and expertise will grow potentially leading to greater diffusion of GIS to other areas of application.

Spatial data needs technology to collect, process and store (Van Loenen 2006). Thus sharing of the spatial data is often advised as a cost-cutting measure. In Malawi, different government ministries and departments and many others are exploring the use of GIS in their activities. This creates an opportunity for sharing spatial information as the underlying spatial data these institutions would like to use is not so different. In fact the study found evidence of spatial information sharing where raster and vector data collected by the Department of Surveys was being made available to MoH. Although this sharing of spatial data has often been unidirectional it has gone a long way in minimizing the effort and the cost in collecting spatial data for MoH.

Furthermore, it is worthy noting that the various institutions exploring GIS in Malawi are already aligned with the NAC and MoH under the multi sectoral national response to HIV/AIDS. Thus, it should be easier for NAC and MoH to use these institutions as sources of spatial data to be used for purposes of monitoring and management of HIV/AIDS.

GIS is a technology initiated and concentrated in the developed world (Dunn et al. 1997). Thus its usage in developing countries like Malawi entails technology transfer through projects initiated or supported by international development agencies or some other representatives of the developed world. This is important in the early stages of GIS adoption as a way of combating the general lack of knowledge and expertise that characterize developing countries, especially in Africa (Hall et al., 1997). For Malawi there are offers of international support towards capacity building in GIS specifically for HIV/AIDS monitoring, evaluation and response. A conference entitled GIS capacity building in Malawi to support HIV/AIDS monitoring, evaluation and response took place on 12th June 2008 with attendance from WHO, University of Pennsylvania in USA, University of Malawi, NAC and MoH. The conference identified training as one of the major needs and ways forward towards capacity building. University of Pennsylvania offered to provide training to local personnel with support from other potential external partners such as ESRI and Loma Lynda University (WHO 2008). Building of local capacity in GIS had been neglected to the detriment of early attempts to bring GIS to important development sectors like health in Africa (Hall et al. 1997). Training creates local expertise for sustainability and scalability of information infrastructures or systems once external support has been withdrawn.

## 7.0 Conclusion

Comparatively, the national level is more ready for GIS than the district level. There are still organizational issues to be dealt with at the district level. For example, the lack of GIS expertise, data continuity, procedures for computation of prevalence levels and aggregation of data for health facility catchment areas need to be addressed. Furthermore, the district level is much exposed to the effects of not having an up-to-date health geospatial register. Without addressing these issues there can only be limited application of GIS at district level. On the other hand, at the national level some of these challenges do not exist or are least severe. In light of this observation, it is recommended that endeavors to use GIS for monitoring and management of HIV/AIDS should start at the national level and trickle down to the district level as the impeding organizational issues are dealt with.

Considering financial and resource constraints faced by the health sector in Malawi it is recommended that spatial data sharing opportunities be fostered. This entails putting in place standards and building partnerships and infrastructure to facilitate the exchange of data. These standards can include agreements on the scaling of spatial data, embedded essential metadata including shape files, codes to identify geographical features and nomenclature. Sharing of spatial data would not only reduce duplication of efforts and produce data of better quality but would also prove attractive to donors as it is more cost-effective.

There is a need to invest resources in building local expertise and capacity in GIS in order to circumvent the problem of lack of expertise and skills. As much as possible, it is recommended that such training should be carried out within participants' operating environment using their own hardware. That is, the training environment should be as close as possible to their operating environment. This will enhance the transfer of experience from training to actual work ensuring participants' productivity in their own working environment. On the other hand, if the technology gap between the training environment and the operating environment is huge the productivity of participants' after the training can be short changed.

## References

1. Balaji, L. (2000). GIS in health. GIS Development. Available at: <http://www.gisdevelopment.net/application/health/overview/health0003.htm> [Accessed on April 7, 2008].
2. Boddy, D., Boonstra, A. & Kennedy, G. (2005). *Managing Information Systems: An Organisational Perspective* 2nd ed., Essex, England: Pearson Education Limited.

3. Dunn, C., Atkins, P. & Townsend, J. (1997). GIS for Development: A Contradiction of Terms? *Area* 97, 29, 151-159.
4. Hall, G., Feick, R. & Bowerman, R. (1997). Problems and Prospects for GIS-based Decision Support Applications in Developing Countries. *South African Journal of Geo-Information*.
5. Hanseth, O. (2002). From systems and tools to networks and infrastructures - from design to cultivation. Towards a theory of ICT solutions and its design methodology implications. Working Paper. University of Oslo, Department of Informatics.
6. Hugo, G. (2000). How Can Spatial Information systems Assist in the Fight Against HIV/AIDS? In National Symposium on 'Every Eight Seconds: AIDS Revisited'. National Library Theatre, Canberra, Australia.
7. Johnson, C. & Johnson, J. (2001). GIS: A Tool for Monitoring and Management of Epidemics. In *Mapping India*. New Delhi, INDIA.
8. Montana, L. et al. (2006). Spatial Modeling of HIV Prevalence in Cameroon, Kenya, and Tanzania, Los Angeles, California: Population Association of America.
9. Saugene, Z.B. (2005). Challenges, Opportunities and Strategies for Using Geographic Information Systems for Public Health Management: An Action Research Study from Mozambique. Master Thesis. University of Oslo, Norway.
10. Tanser, F. & Sauer, D., 2002. The application of geographical information systems to important public health problems in Africa. *International Journal of Health Geographics*, 1(4), 4-12.
11. Tanser, F.C. (2000). The Application of Geographical Information Systems to Infectious Diseases and Health Systems in Africa. PhD Thesis. University of Natal, Durban.
12. Van Loenen, B. (2006). Developing Geographic Information Infrastructures: The role of information policies, Delft, Netherlands: Delft University Press.
13. Vanmeulebrouk, B. et al. (2008). Open Source GIS for HIV-AIDS Management. *International Journal of Health Geographics*, 7(53).
14. WHO (2008). GIS capacity building in Malawi to support HIV/AIDS monitoring, evaluation and response. In Lilongwe, MALAWI: World Health Organisation

## **FACULTY OF THE BUILT ENVIRONMENT**

The faculty of the Built Environment is the newest faculty at the Malawi Polytechnic. The faculty was officially launched by the Ministry of Lands, Housing and Urban Development in 2006. It grew out from the Faculty of Engineering. Currently, the Faculty of Built Environment has three departments; Architecture Department, Land Surveying Department and Quantity Surveying Department. It started offering undergraduate degree programmes in Architectural Studies, Land Surveying and Quantity Surveying in 2003. In 2006 the faculty also introduced degree programmes in Land Economy and Physical Planning.

Apart from offering academic programs the faculty has been instrumental in guiding the Malawi Polytechnic, the City of Blantyre and Malawi Government on proper ways to utilize the land available. The faculty is also involved in research.

The Faculty of Built Environment seeks to produce the highest quality personnel to drive the Malawi nation's development agenda. In line with this goal, the faculty of the Built Environment has 31 well trained academic members of staff who teach the academic programmes as well as carry out research in different areas. Looking further to the future, the Faculty of Built Environment hopes to add Landscape Architecture to the course Curricula, along with other Post Graduate courses such as Housing Studies, Land Management and Land Tenure Studies.

# LEAD LEVELS IN LIPSTICKS AND EYE SHADOWS COMMONLY SOLD IN BLANTYRE CITY, MALAWI

W Utembe<sup>a</sup>, S.E Kaphika<sup>b</sup> and DD Lakudzala<sup>c</sup>

<sup>a</sup>Department of Physics and Biochemical Sciences, Malawi Polytechnic, University of Malawi, Private bag 303, Chichiri, Blantyre 3

Phone: +2651872911; Fax: (+265) 1 870 578; Email wutembe@poly.ac.mw

<sup>b</sup>Department of Physics and Biochemical Sciences, Malawi Polytechnic, University of Malawi, Email: kaphikaephraim@gmail.com

<sup>c</sup>Department of Physics and Biochemical Sciences, Malawi Polytechnic, University of Malawi, Email: dlakudzala@poly.ac.mw

## Abstract

Lead is a chronic neurotoxicant. It is sometimes added to cosmetic products as a color pigment. The aim of this study was to determine the concentrations of lead in lipstick and eye shadow products sold in Blantyre City. Samples of lipsticks and eyeshadow products obtained from markets in Blantyre were digested using acids. Concentrations of lead were measured using flame atomic absorption spectrophotometer. The concentrations of lead in lipstick varied greatly between the different brands of lipsticks, ranging from below limit of detection (0.001 ppm) to 53.330 ppm. Fifteen of the 20 samples had lead levels significantly higher than the MBS limit. All of the 16 eye shadow samples had lead levels much significantly higher than the MBS limit, with concentrations ranging from 70.00 ppm to 491.6 ppm. The average lead content in eye shadows (263.58 ppm) was much higher than the mean concentration of lead in lipsticks (20.28 ppm). There is a high chance that lead applied to lips through lipstick can end up being ingested. The lead in eye shadow can also be absorbed through healthy skin. Therefore, this study has shown that the use of lipsticks and eye shadow products in Malawi can expose users to significant levels of lead. Thus, there is a need for stricter enforcement of the Malawi standard on lead on cosmetics. The Pharmacies Medicines and Poisons Board, Consumers Association of Malawi and other stakeholders are urged to sensitize consumers on the risks posed by the use of some cosmetic products.

Keywords: Lead, lipstick, eye shadow, cosmetics, exposure, risk

## 1.0 Introduction

Leaded petrol, lead-ore mining and processing and lead-based paints are historically the main sources of the lead (Pb) to which people are exposed. However, studies in other countries have shown that people can be exposed to lead through the use of cosmetics. Cosmetics include skin-care creams, lotions, powders and sprays, perfumes, lipsticks, fingernail polishes, eye and facial makeup, permanent waves, hair colors, deodorants, baby products, bath and shower oils and creams, toothpaste, sunscreens, and other related products (Bocca et al., 2014). In cosmetics lead is either added as a color pigment or it is available as an impurity in the raw materials (Sainio et al., 2000; Piccinini et al., 2013).

Lead is hazardous to human beings, especially young children. It is known to alter the cellular metabolism of calcium, inhibit the normal functioning of some enzymes, stimulate synthesis of binding proteins in kidney, brain, and bone, and slow down nerve conduction (Patočka and Černý, 2003). These actions can result in, among other things, anaemia, chronic nephropathy, hypertension, impaired neurobehavioral development, reproductive impairment, reduced intelligent quotient and delinquent behaviour (Landrigan et al., 1976; Gerber et al., 1980; Landrigan, 1989; Goyer, 1990a; Pocock et al., 1994; Schwartz, 1994; Todd et al., 1996; Needleman et al., 2002; Patrick, 2006).

Widely recognized sources of lead include lead water pipes and drinking water (Englert and Höring, 1994; Meyer et al., 1998; Edwards et al., 2009), leaded petrol, children's toys (Kumar and Pastore, 2007), lead based paint (Clark et al., 2006; Kumar and Gottesfeld, 2008; Clark et al., 2009; Lin et al., 2009), lead acid batteries, lead glazed kitchenware (Sheets, 1998), contaminated food (Sherlock, 1987; Wilhelm et al., 2003; Muñoz et al., 2005; Rubio et al., 2005; EFSA, 2010) mining and processing of lead ore (Dooyema et al., 2012; Lo et al., 2012) and contaminated traditional medicine (Healy et al., 1984; Saper et al., 2004; Karri et al., 2008). Many countries regulate various sources of lead especially leaded petrol and lead based paints. Malawi phased out the use of leaded petrol in 2006. Although cosmetics may be a minor source of lead exposure compared to other sources, repetitive application of lead-containing cosmetics can lead to significant exposure levels, particularly for those women who use cosmetics regularly (Brandao et al., 2012). The Malawi Bureau of Standards (MBS) monitors lead in cosmetics through the implementation of Skin care products specification (MS 334: 1991).

A literature search did not find any published data on levels of lead in cosmetic products in Malawi. Therefore, the study aims to determine the concentrations of lead in samples of lipsticks and eye shadows found in Blantyre

City, Malawi and to assess the safety of these products for human use.

## 2.0 Method

### 2.1 Sample collection, preparation and analysis

Forty samples of commonly available lipsticks and sixteen samples of eye shadows were locally purchased from different shops and markets within the city of Blantyre. The samples were transported to the Malawi Polytechnic Department of Physics and Biochemical Sciences Chemistry laboratory for analysis. Apparatus such as glassware were washed with liquid soap, soaked in 10 v/v % nitric acid for 24hrs and cleaned thoroughly with distilled water to avoid contamination. Duplicate samples (2g) were digested in nitric acid and sulphuric acid. After cooling the digested samples were each transferred into 100ml volumetric flask and their volume adjusted to 100 ml with distilled water. The digested samples were analysed for lead on an atomic absorption spectrophotometer (GBC 932) with a hollow cathode lamp and a deuterium lamp for background correction (AOAC, 2000).

### 2.2 Administration of questionnaires

Questionnaires were administered to 50 randomly selected lipstick users so as to solicit information on use patterns of the products. Respondents consented to taking part in the research. However, shop owners were not aware that the lipstick and eye shadows were being bought for lead analysis.

### 2.3 Data analysis

All results obtained were recorded, processed and analyzed statistically using SPSS version 16 for windows. Although the Maximum likelihood estimation and Regression on Order Statistics (ROS) give better results (Newman et al., 1989; Helsel, 2010), because of lack of necessary software substitution methods (i.e. substitution of LOD with  $LOD/\sqrt{2}$ ) was used to analyze left censored data (cases where the lead content was below the detection limit (LOD)). The student's t-test was used to test the significance of differences between content of lead in the product and the standard values.

## 3.0 Results

The concentrations of lead varied greatly between the different brands of lipsticks, ranging from below limit of detection (0.001 ppm) to  $53.330 \pm 5.9$  ppm ( $\mu\text{g/g}$ ). The average lead content in the all samples was 20.2834 ppm. Lead was not detected in only 4 of the 20 brands analyzed. Fifteen of the 20 samples (75%) had lead levels significantly higher than the MBS limit of 0.1 ppm ( $\mu\text{g/g}$ ) (MBS, 2013). The results of lead in the 20 brands of lipsticks are shown in Table 1 below.

Unlike in lipsticks, lead was detected in all the 16 samples of eye shadows. The concentrations ranged from  $70.00 \pm 2.80$  ppm to  $491.6 \pm 1.0$  ppm, with a mean content of 263.58 ppm. All of the 16 samples had lead levels much significantly higher than the MBS limit. The results showed the average lead content in eye shadows was much higher than the mean concentration of lead in lipsticks. The results of lead in the 6 brands of eye shadow products are shown in Table 2 below.

**Table 1: Content of lead in lipsticks sampled from shops and markets in Blantyre**

Lipstick	Concentration of lead (ppm)
A	$0.41 \pm 0.06$
B	$17.30 \pm 0.03$
C	$5.88 \pm 0.10$
D	$16.57 \pm 0.40$
E	$23.02 \pm 0.01$
F	ND*
G	$53.3 \pm 5.9$
H	ND
I	$0.16 \pm 0.20$
J	ND
K	$0.51 \pm 0.7$
L	$39.57 \pm 0.18$
M	$50.7 \pm 0.13$



N	17.3 ± 0.2
O	ND
P	0.51 ± 0.71
Q	39.6 ± 0.18
R	50.7 ± 1.3
S	19.11 ± 0.02
T	44.9 ± 1.2
U	0.0440 ± 0.001
* ND Not Detected	

**TABLE 2: Content of lead in eye shadows sampled from shops and markets in Blantyre**

Sample of Eyeshadow	Concentration of lead (ppm)
A	70.0±2.8
B	249.7±0.6
C	204.2±5.5
D	165.1±1.4
E	491.6±1.0
F	406.9±0.4

#### 4.0 Discussion

A thorough review of toxic metals in cosmetic products in different countries has recently been done by Bocca et al (2014). In 13 different studies 3.5% of samples of 1300 lip products (including lipsticks, lip gloss and lip balm) tested contained Pb above 10 µg/g. The 10 µg/g in cosmetics is the level considered to be technically feasible for manufacturers according to Canadian guidelines. However, the 96.5% of lip products contained concentration lower than 10 µg/g with the lowest level of Pb detected in lipsticks being around 0.1 µg/g. These results show that Pb levels much lower than 10 µg/g are feasible (Bocca et al., 2014).

A European survey on the content of lead in lip products showed that 31% of the tested lipsticks and 4% of lip glosses contained lead at higher levels than 1 ppm. The lead content of lipsticks (0.75 ppm) was nearly double that of lip glosses (0.38 ppm) (Piccinini et al., 2013). In South Africa only 25% of the 40 samples of lipsticks were found to meet the requirement (Brandao et al., 2012). In one study in Saudi Arabia lead was detected in all the 26 different brands of lipsticks and 8 brands of eye: The median lead content in the lipstick samples was 0.73 ppm on wet basis; there were four brands of lipsticks with lead content above the USFDA lead limit of colour additives (20 ppm) (Al-Saleh and Al-Enazi, 2011). Yet another study from the same Saudi Arabia found levels of lead in 14 brands of lipstick to be below the US Food and Drug Administration for metallic impurities in colour additives used in cosmetics (Al-Saleh and Al-Enazi, 2011). In Nigeria, samples of eye liners contained an average of 130 µg/g and eye pencils contained 120 µg/g (Nnorom et al., 2005). A study in Iran showed that 95.91% of lipsticks from China had a mean lead content of much higher than 20 µg/g whereas all lipsticks from Iran had lead content lower than 10 µg/g (Ziarati et al., 2012).

These studies show that the presence of high levels of lead in cosmetic products is an international problem. The studies have also shown that different countries can have cosmetic products that contain different levels of lead, with some being very high, even over 100 µg/g. Differences among the studies may reflect variations in Pb content among the specific products tested, although different digestion techniques employed may also result in differences in levels of digestion of the samples (Liu et al., 2013).

The main routes of exposure of lead are oral ingestion and inhalation; however, dermal absorption is also possible (Bocca et al., 2014). Lipsticks and eye shadows are not rinsed-off shortly after application but are left and may remain in contact with the skin over several hours. Although, not all of the lead applied on lips results into uptake into the body, there is a high chance that lead applied to lips through lipstick can end up being ingested while eating food as the food is likely to come in direct contact with one's lips. In addition, the tendency of sucking one's lips may result in a gradual ingestion of the product. It is also possible that lead applied from eye shadow can be absorbed through the skin. Although it is not clear as to how much the skin can absorb, the average quantity of lead found in these products is much great and likely to increase the risk of exposure.

From the questionnaires it was shown that the average period it takes to finish one lipstick by an individual

user was 168 days. Using this value and the lead content in the lipsticks it can be estimated that the daily lead exposure is  $0.302\mu\text{g Pb/day}$ , the least exposure being  $0.0007\mu\text{g Pb/day}$  and the highest  $0.794\mu\text{g Pb/day}$ . Other investigators have estimated much higher average daily exposures: 24 mg/day of lead from lip products from average daily lipstick usage of 2.35 times per day at an application rate of 10 mg of product at each use) (Liu et al., 2013). Lead appears to have no safety threshold so that regulatory organizations such as the United States Environmental Programme (USEPA) have desisted from issuing reference dose (USEPA, 2004). For similar reasons the World Health Organization (WHO) suspended the Provisional Weekly Intake (PTWI) for lead in 2010 after concluding that the PTWI could no longer be considered protective to health (WHO, 2011). One thing that can be said though is that the lead content in lipsticks and eyeshadow products sold in Blantyre are significantly above the 0.1 ppm maximum permissible limit of lead in cosmetics set in MS 334: 2013.

Women who use these cosmetics daily may be exposed to high levels of lead. This exposure may have particularly significant implications for children. Maternal and foetal blood lead levels are known to be nearly identical, showing that lead easily passes through the placenta (Goyer, 1990b; Silbergeld, 1991). Levels of lead in breast milk have a strong influence on infant blood lead levels over and above the influence of maternal blood lead (Li et al., 2000; Ettinger et al., 2004). Lead can cause neurobehavioral effects in infants and children (Dietrich et al., 1987; Goyer, 1996; Gomaa et al., 2002; Hu et al., 2006). Prenatal and postnatal exposures to lead have been linked to delinquent behaviour (Needleman et al., 2002; Wright et al., 2008). Therefore, use of lead contaminated cosmetics such as lipstick or eye shadows by pregnant or/and lactating women could put the foetus and infants, who are very vulnerable to effects of lead, at risk.

In the European Union, the presence of lead in cosmetic products is forbidden except from the small quantities stemming from impurities of natural or synthetic ingredients, the manufacturing process, storage, migration from packaging, as long as the product is safe for human health when used under normal or reasonably foreseeable conditions of use (Piccinini et al., 2013). In the United States of America (USA) dyes and pigments used as ingredients in cosmetics are regulated as color additives by the United States Food and Drug Administration (USFDA). All colour additives must be tested for safety and approved for their intended use by the United States Food and Drug Administration (USFDA) before they can be marketed in the United States of America (USA). The USFDA limit for lead in colour additives is 20ppm (Hepp et al., 2009). Though the USFDA's recommended lead limit in cosmetics is far much above than the Malawi standard, it was noted that all eye shadows and 45% of lipstick samples had levels beyond the USFDA's 20 ppm maximum allowable level.

There is no evidence for a threshold for health effects induced by lead. Therefore, measures must be taken to limit human exposure to lead by, among other things, controlling the content of lead in consumer products (Piccinini et al., 2013). This is proving to be a difficult task for Malawi because of lack of resources, corruption, smuggling and porosity of the country's borders (Jali, 2013). It is therefore the duty of suppliers to get their products to undergo quality checks at the MBS laboratories. However, this cannot be a reliable measure as most suppliers shun this duty as they try to avoid cost of getting such services at the MBS.

During this study it was observed that most users of these products are not aware that toxic substances such as lead could be found in lipstick and eye-shadows. This means that most people are using these products without any caution and may probably be exposing themselves to lead through ignorance. The Pharmacies Medicines and Poisons Board, Consumers Association of Malawi (CAMA) and other Nongovernmental Organizations (NGOs) are therefore urged to collaborate and intensify their efforts in sensitizing consumers on the potential risks associated with the use of some cosmetic products.

## 5.0 Conclusion and recommendations

Lead was found in all eye shadows tested in this study and the lead values were about 26,359 times above the recommended limit. Only 20% of lipstick complied with the requirements set forth in the local standard (MS 334: 2013). On average lipsticks contained about 203 times the recommended limit in MS 334: 2013.

The present study has shown that the use of lipsticks and eye shadows in Malawi can expose users to significant levels of lead. Pharmacies Medicines and Poisons Board, Consumers Association of Malawi (CAMA) and other stakeholders should intensify consumer awareness on toxic ingredients in cosmetic products. Manufacturers are urged to make sure that their products and the ingredients used in the manufacture of their products are safe. Consumers should take the responsibility of reading the contents of products they use and purchasing products whose contents have been properly declared.

## References

1. Al-Saleh, I., Al-Enazi, S., 2011. Trace metals in lipsticks. *Toxicological & Environmental Chemistry* 93, pp.1149-1165.

2. Bocca, B., Pino, A., Alimonti, A., Forte, G., 2014. Toxic metals contained in cosmetics: A status report. *Regulatory Toxicology and Pharmacology* 68, pp. 447-467.
3. Brandao, J., Okonkwo, O., Sehkula, M., Raseleka, R., 2012. Concentrations of lead in cosmetics commonly used in South Africa. *Toxicological & Environmental Chemistry* 94, pp 70-77.
4. Clark, C.S., Rampal, K.G., Thuppil, V., Chen, C.K., Clark, R., Roda, S., 2006. The lead content of currently available new residential paint in several Asian countries. *Environmental Research* 102, pp. 9-12.
5. Clark, C.S., Rampal, K.G., Thuppil, V., Roda, S.M., Succop, P., Menrath, W., Chen, C.K., Adebamowo, E.O., Agbede, O.A., Sridhar, M.K.C., Adebamowo, C.A., Zakaria, Y., El-Safty, A., Shinde, R.M., Yu, J., 2009. Lead levels in new enamel household paints from Asia, Africa and South America. *Environmental Research* 109, pp. 930-936.
6. Dietrich, K.N., Krafft, K.M., Bornschein, R.L., Hammond, P.B., Berger, O., Succop, P.A., Bier, M., 1987. Low-Level Fetal Lead Exposure Effect on Neurobehavioral Development in Early Infancy. *Pediatrics* 80, pp. 721-730.
7. Dooyema, C.A., Neri, A., Lo, Y.-C., Durant, J., Dargan, P.I., Swarthout, T., Biya, O., Gidado, S.O., Haladu, S., Sani-Gwarzo, N., 2012. Outbreak of fatal childhood lead poisoning related to artisanal gold mining in northwestern Nigeria, 2010. *Environmental Health Perspectives* pp. 120, 601.
8. Edwards, M., Triantafyllidou, S., Best, D., 2009. Elevated Blood Lead in Young Children Due to Lead-Contaminated Drinking Water: Washington, DC, 2001–2004. *Environmental Science & Technology* 43, pp. 1618-1623.
9. EFSA, 2010. Scientific Opinion on Lead in Food. *EFSA Journal* 8(4):pp. 1570.
10. Englert, N., Höring, H., 1994. Lead concentration in tap-water and in blood of selected schoolchildren in Southern Saxonia. *Toxicology Letters* 72, pp. 325-331.
11. Ettinger, A.S., Téllez-Rojo, M.M., Amarasiriwardena, C., Bellinger, D., Peterson, K., Schwartz, J., Hu, H., Hernández-Avila, M., 2004. Effect of breast milk lead on infant blood lead levels at 1 month of age. *Environmental health perspectives* 112, pp. 1381.
12. Gerber, G.B., Léonard, A., Jacquet, P., 1980. Toxicity, mutagenicity and teratogenicity of lead. *Mutation Research/Reviews in Genetic Toxicology* 76, pp. 115-141.
13. Gomaa, A., Hu, H., Bellinger, D., Schwartz, J., Tsaih, S.-W., Gonzalez-Cossio, T. Schnaas, L., Peterson, K. Aro, A., Hernandez-Avila, M., 2002. Maternal bone lead as an independent risk factor for fetal neurotoxicity: a prospective study. *Pediatrics* 110, pp. 110-118.
14. Goyer, R.A., 1990a. Lead toxicity: from overt to subclinical to subtle health effects. *Environmental Health Perspectives* 86, pp. 177.
15. Goyer, R.A., 1990b. Transplacental transport of lead. *Environmental health perspectives* 89, pp. 101.
16. Goyer, R.A., 1996. Results of lead research: prenatal exposure and neurological consequences. *Environmental health perspectives* 104, pp. 1050.
17. Healy, M.A., Aslam, M., Bamgboye, O.A., 1984. Traditional medicine and lead-containing preparations in Nigeria. *Public Health* 98, pp. 26-32.
18. Helsel, D., 2010. Much ado about next to nothing: incorporating nondetects in science. *Annals of occupational hygiene* 54, pp.257-262.
19. Hepp, N.M., Mindak, W.R., Cheng, J., 2009. Determination of total lead in lipstick: development and validation of a microwave-assisted digestion, inductively coupled plasma-mass spectrometric method. *Journal of cosmetic science* 60, pp.405.
20. Hu, H., Téllez-Rojo, M.M., Bellinger, D., Smith, D., Ettinger, A.S., Lamadrid-Figueroa, H., Schwartz, J., Schnaas, L., Mercado-García, A., Hernández-Avila, M., 2006. Fetal lead exposure at each stage of pregnancy as a predictor of infant mental development. *Environmental health perspectives* 114, pp.1730.
21. Jali, K., 2013. Porous borders affecting certification of goods. *The Daily Times*, 27th October 2013, Blantyre.
22. Karri, S.K., Saper, R.B., Kales, S.N., 2008. Lead encephalopathy due to traditional medicines. *Current drug safety* 3, pp.54.

23. Kumar, A., Gottesfeld, P., 2008. Lead content in household paints in India. *Science of The Total Environment* 407, pp.333-337.
24. Kumar, A., Pastore, P., 2007. Lead and cadmium in soft plastic toys. *CURRENT SCIENCE* 93, pp.818.
25. Landrigan, P.J., 1989. Editorial: Toxicity of Lead at Low Dose. *British Journal of Industrial Medicine* 46, pp.593-596.
26. Landrigan, P.J., Baker Jr, E.L., Feldman, R.G., Cox, D.H., Eden, K.V., Orenstein, W.A. Mather, J.A., Yankel, A.J., Lindern, I.H.v., 1976. Increased lead absorption with anemia and slowed nerve conduction in children near a lead smelter. *The Journal of Pediatrics* 89, pp. 904-910.
27. Li, P., Sheng, Y., Wang, Q., Gu, L., Wang, Y., 2000. Transfer of lead via placenta and breast milk in human. *Biomedical and environmental sciences: BES* 13, 85-89.
28. Lin, G.Z., Peng, R.F., Chen, Q., Wu, Z.G., Du, L., 2009. Lead in housing paints: An exposure source still not taken seriously for children lead poisoning in China. *Environmental Research* 109, pp.1-5.
29. Liu, S., Hammond, S., Rojas-Cheatham, A., 2013. Concentrations and potential health risks of metals in lip products. *Environmental health perspectives* 121, pp.705-710.
30. Lo, Y.-C., Dooyema, C.A., Neri, A., Durant, J., Jefferies, T., Medina-Marino, A. de Ravello, L., Thoroughman, D., Davis, L., Dankoli, R.S., 2012. Childhood lead poisoning associated with gold ore processing: a village-level investigation—Zamfara State, Nigeria, October–November 2010. *Environmental Health Perspectives* 120, pp. 1450.
31. MBS, 2013. MS 334: 1991: Skin care products specification. Blantyre.
32. Meyer, I., Heinrich, J., Trepka, M.J., Krause, C., Schulz, C., Meyer, E., Lippold, U. 1998. The effect of lead in tap water on blood lead in children in a smelter town. *Science of The Total Environment* 209, pp. 255-271.
33. Muñoz, O., Bastias, J.M., Araya, M., Morales, A., Orellana, C., Rebolledo, R., Velez, D., 2005. Estimation of the dietary intake of cadmium, lead, mercury, and arsenic by the population of Santiago (Chile) using a Total Diet Study. *Food and Chemical Toxicology* 43, pp. 1647-1655.
34. Needleman, H.L., McFarland, C., Ness, R.B., Fienberg, S.E., Tobin, M.J., 2002. Bone lead levels in adjudicated delinquents: A case control study. *Neurotoxicology and Teratology* 24, pp. 711-717.
35. Newman, M.C., Dixon, P.M., Looney, B.B., Pinder, J.E., 1989. ESTIMATING MEAN AND VARIANCE FOR ENVIRONMENTAL SAMPLES WITH BELOW DETECTION LIMIT OBSERVATIONS1. *JAWRA Journal of the American Water Resources Association* 25, pp. 905-916.
36. Nnorom, I., Igwe, J., Oji-Nnorom, C., 2005. Trace metal contents of facial (make-up) cosmetics commonly used in Nigeria. *African Journal of Biotechnology* 4.
37. Patočka, J., Černý, K., 2003. Inorganic lead toxicology. OF THE CHARLES UNIVERSITY FACULTY OF MEDICINE AND UNIVERSITY HOSPITAL” 22 JANUARY 2003, HRADEC KRÁLOVÉ 46, pp 65-72.
38. Patrick, L., 2006. Lead Toxicity, A Review of the Literature. Part 1: Exposure, Evaluation, and Treatment. *Alternative Medicine Review* 11, pp. 2-23.
39. Piccinini, P., Piecha, M., Torrent, S.F., 2013. European survey on the content of lead in lip products. *Journal of pharmaceutical and biomedical analysis* 76, pp. 225-233.
40. Pocock, S.J., Smith, M., Baghurst, P., 1994. Environmental lead and children’s intelligence: a systematic review of the epidemiological evidence. *British Medical Journal* 309, pp. 189-197.
41. Rubio, C., Gonzalez-Iglesias, T., Revert, C., Reguera, J.I., Gutierrez, A.J., Hardisson, A. 2005. Lead Dietary Intake in a Spanish Population (Canary Islands). *Journal of Agricultural and Food Chemistry* 53, pp. 6543-6549.
42. Sainio, E.L., Jolanki, R., Hakala, E., Kanerva, L., 2000. Metals and arsenic in eye shadows. *Contact Dermatitis* 42, pp. 5-10.
43. Saper, R.B., Kales, S.N., Paquin, J., Burns, M.J., Eisenberg, D.M., Davis, R.B. Phillips, R.S., 2004. Heavy metal content of ayurvedic herbal medicine products. *Jama* 292, pp. 2868-2873.
44. Schwartz, J., 1994. Low-Level Lead Exposure and Children’s IQ: A Metaanalysis and Search for a Threshold. *Environmental Research* 65, pp. 42-55.
45. Sheets, R., 1998. Release of heavy metals from European and Asian porcelain dinnerware. *Science of The Total Environment* 212, pp. 107-113.
46. Sherlock, J., 1987. Lead in food and the diet. *Environmental Geochemistry and Health* 9, pp. 43-47.
47. Silbergeld, E.K., 1991. Lead in bone: implications for toxicology during pregnancy and lactation. *Environmental health perspectives* pp. 91, 63.
48. Todd, A., Wetmur, J., Moline, J., Godbold, J., Levin, S., Landrigan, P., 1996. Unraveling the Chronic Toxicity of Lead: An Essential Priority for Environmental Health. *Environmental Health Perspectives* 4, pp. 141-146.
49. USEPA, 2004. Integrated Risk Information System: Lead and compounds (inorganic) (CASRN 7439-92-1) [online]. Viewed 10th April 2014 Available at: <<http://www.epa.gov/iris/subst/0277.htm>>
50. WHO, 2011. Evaluations of the Joint FAO/WHO Expert Committee on Food Additives (JECFA): LEAD. [On

- line], Viewed on 9th April, 2014, Available at: <<http://apps.who.int/food-additives-contaminants-jecfa-database/chemical.aspx?chemID=3511>> [Accessed 22/04/2014]>
51. Wilhelm, M., Wittsiepe, J., Schrey, P., Feldmann, C., Idel, H., 2003. Dietary intake of lead by children and adults in Germany measured by the duplicate method. *International Journal of Hygiene and Environmental Health* 206, pp. 93-503.
52. Wright, J.P., Dietrich, K.N., Ris, M.D., Hornung, R.W., Wessel, S.D., Lanphear, B.P., Ho, M., Rae, M.N., 2008. Association of prenatal and childhood blood lead concentrations with criminal arrests in early adulthood. *PLoS Medicine* 5, pp. e101.
53. Ziarati, P., Moghimi, S., Arbabi-Bidgoli, S., Qomi, M., 2012. Risk Assessment of Heavy Metal Contents (Lead and Cadmium) in Lipsticks in Iran. *International Journal of Chemical Engineering and Applications* 3, pp. 450-452.

# SUSTAINABILITY OF WATER KIOSKS IN LOW- INCOME AREAS OF BLANTYRE CITY IN MALAWI

A. Samson<sup>a</sup>, P.N. Zuzani<sup>a\*</sup> and U.B. Mughogho<sup>a</sup>

<sup>a</sup> University of Malawi, The Polytechnic, \*P/Bag 303, Chichiri, Blantyre 3, Malawi; <sup>a\*</sup>pzuzani@poly.ac.mw; Phone: +265 (0) 1 870 411 / +265 (0) 888 337 550; Fax: +265 (0) 1 870 578;

## Abstract

Most Low-Income Areas in cities of developing countries like Malawi face numerous challenges to access potable water. Water kiosks have proven to be an appropriate solution in most cases. In Blantyre City, most areas are currently under this arrangement. A major challenge, however, has been that many households are not properly served; unsecure and unreliable sources such as shallow wells and springs are used instead. This study investigated the sustainability of water kiosks in Low-Income Areas of Blantyre City. The study areas were Bangwe, Chilomoni, Kachere-Nkolokoti and Nancholi. The study used multi-criteria analysis, which focuses on four main criteria that affect sustainability of water supplies namely: technical, financial, social/environmental and institutional. This was done using informant interviews, structured questionnaires, focus group discussions and observations. The sustainability categories used were: sustainable (70-100%), partially sustainable (30-70%) and unsustainable (<30%).

Results have shown that water kiosks in low-income areas of Blantyre City are partially-sustainable with Bangwe at 54.2%, Chilomoni at 66.7%, Kachere-Nkolokoti at 60.1% and Nancholi at 67.2%. This is attributed to mainly technical problems such as failure to maintain design flow, inadequate design of feeder tanks for all study areas and lower capacity of the system to meet additional demand. To ensure full sustainability, this study recommends that water production capacity be increased by repairing or replacing worn out pumps and/or replacing of worn out pipes. It is also recommended that for proper operation, management and maintenance of water kiosks, there is need to have a robust financial and institutional governance structures by all concerned stakeholders.

Keywords: Blantyre City; Low-Income Areas; Sustainability; Water Kiosks,

## 1.0 Introduction

Blantyre Water Board (BWB) is a sole water utility company in Malawi that supplies water to Blantyre City. Some of the areas in this city catered by BWB are Low Income Areas (LIAs). LIAs in Malawi are unplanned urban settlements whose residents are predominantly poor. In the past, Blantyre City Council (BCC), who is the landlord of the city did not promote supply of individual house piped water to these areas due to their unplanned nature (Chirwa and Junge, 2007). Instead, communal water points (kiosks), as a means of supplying water were encouraged. These settlements are mushrooming thereby increasing the areas which are not served with water and sanitation services.

Supply of piped water in these areas has proven to be difficult as the majority of the residents cannot afford to pay for and maintain a household connection. In addition, the distribution system cannot be extended into LIAs due to the high density of housing (GTZ, 2009). The ability of water utilities to serve the LIAs is also restricted by legal and other considerations. These include lack of land tenure in LIAs, which limits the ability of the poor to demand or qualify for direct access to formal services under existing legal and regulatory frameworks. In the meantime, granting tenure may be the subject of other government reform measures, and is invariably outside the mandate of water utilities (Chirwa and Junge, 2007).

As one way of developing such areas, the Government of Malawi is undertaking a wide range of reforms in the water sector. One of the objectives of MGDS (2006) is increasing availability and access of safe water to people. Most people living in LIAs in cities of developing countries like Malawi face numerous challenges to access potable water. Water Kiosks, where formal water providers supply safe water at affordable prices have therefore proven to be an appropriate solution in most cases. In Blantyre City, most areas are currently under these water kiosk arrangements. A major challenge, however has been that a large number of households are not properly served; unsecured sources that are often unreliable are sought instead. This study investigated the sustainability of water kiosks in low-income areas of Blantyre City. The study areas were Bangwe, Chilomoni, Kachere-Nkolokoti and Nancholi. The main objective was to assess the sustainability of these water kiosks by considering all significant criteria that affect sustainability of any water supply scheme such as technical, financial, institutional and social and environmental.

Though BWB already put in place a few water kiosks in such areas, the introduction of MDGs has seen donor

interest to increase the availability of water kiosks in many other LIAs. In the recent past, BWB entered into a Service Contract agreement with Vitens-Evides International (as a form of Public Private Partnerships), with an aim of reaching out to many un-served communities which include high density LIAs. Among the indicators of the project, extension of water supply to LIAs was one of the major outputs that were expected by the end of the project in 2013. In addition to the already existing water kiosks, BWB was to construct 363 kiosks under the project.

**2.0 Materials and Methods**

**2.1 Study Areas**

To conduct this study, four low-income areas of Blantyre City were considered namely: Bangwe, Chilomoni, Kachere-Nkolokoti and Nancholi. Choice of the area was based on notable water supply problems being experienced in these areas. Table 1 gives details of each of the four study areas and Figure 1 is a map of Blantyre city showing the four areas under study.

**Table 1: Details of the four study areas**

Name of LIA	Location (in Blantyre City)	Management style	Capacity of feeder tank (m <sup>3</sup> )	Tank elevation using intake as datum (m)	Distribution system	Flow Rate in the system (m <sup>3</sup> /hr)
Bangwe	South-East	WUA	9,092	1213	Grid and Branching	0-300
Chilomoni	North-West	WUA	13,500	1112	Grid and Branching	0-300
Nancholi	South-West	WUA	2,500	1058	Grid and Branching	0-300
Kachere-Nkolokoti	North-East	WUA	4,958	1153	Grid and Branching	0-300

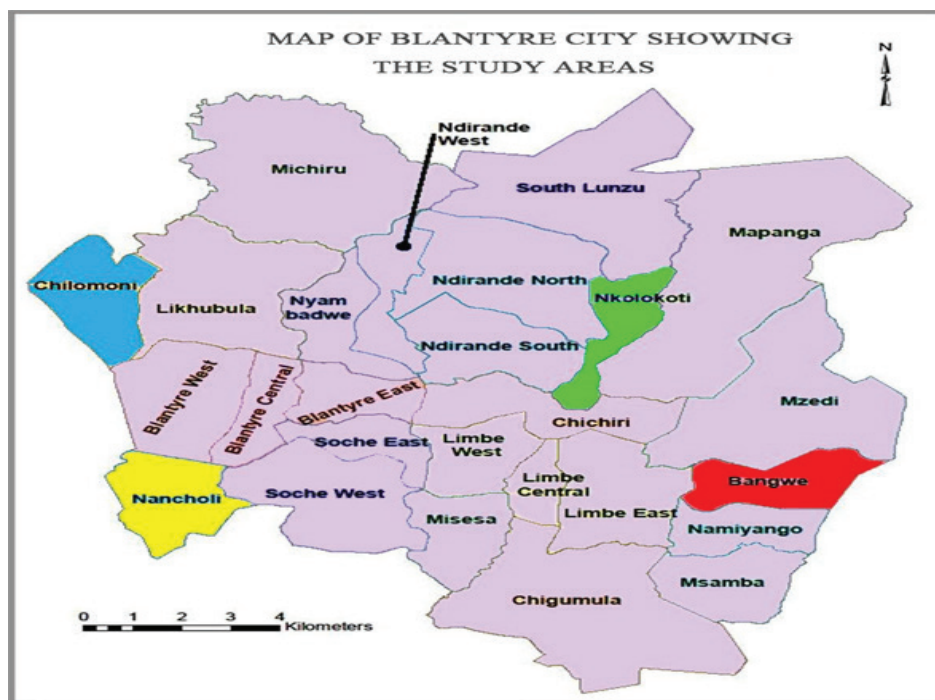

**Figure 1: Map of Blantyre City showing the four study areas**

## 2.2 Research Approach

This study used the multi-criteria analysis, which was adapted from Panthi and Bhattarai (2008). Using this approach, focus was on four main aspects/criteria that affect sustainability of a water supply scheme namely: technical, social/environmental, financial and institutional as shown in Figure 2. These main criteria were used to assess whether a water supply scheme is sustainable or not.



**Figure 2: Main criteria that affect sustainability of water supply scheme**

These criteria were divided into thirteen (13) main variables, which were further sub-divided into twenty-six (26) sub-variables as shown in Table 2. The sub-variables are the indicators of sustainability under each main variable. Each sub-variable was assigned a weight of importance depending on its influence on sustainability of a water supply project. The sub-variables were again measured, judged or rated at each of the four study areas to establish variable rate. Each sub-variable was rated for each individual LIA on a three-point scale: sustainable (70-100%), partially sustainable (30-70%) and unsustainable (<30%) to give the final sustainability status (Table 3). Then each variable rate was multiplied by the weight assigned to it earlier to obtain the final sustainability score.

**Table 2: Criteria, Main variables, Sub variables and Weights for the Sustainability scores**

Criteria	Main Variable	Sub Variable	Weight
1. Technical	1.1 Source yield and quality	1.1.1 Reliability, adequacy, depletion	0.054
		1.1.2 Water quality at source	0.023
		1.1.3 Accessibility, chance of contamination & conflict	0.023
	1.2 Physical condition of system	1.2.1 Design adequacy, site & technology	0.008
		1.2.2 Condition & functionality of system	0.054
		1.2.3 Natural threat to physical system	0.038
	1.3 Water point functioning	1.3.1 Maintaining design flow	0.120
1.3.2 Water quality		0.040	
1.3.3 Surrounding condition/Drainage system		0.040	
1.4 Meeting demand	1.4.1 Water fetching time	0.070	
	1.4.2 Status of meeting addition demand	0.030	
2. Social/ Environmental	2.1 Use of water facility	2.1.1 Status of use by targeted population	0.100
	2.2 Community participation	2.2.1 Decision making and O&M	0.050
	2.3 Environmental	2.3.1 Mitigation measures and drainage	0.050
	2.4 Social inclusion & equity	2.4.1 Inclusion (ethnic group)	0.031
3. Financial	3.1 Availability of fund	3.1.1 Establishment of O&M fund	0.025
		3.1.2 Regularity and Transparency	0.015
	3.2 Use of fund	3.2.1 Use of savings / surplus fund	0.010
4. Institutional	4.1 Users' committee	4.1.1 Existence, functioning and meetings	0.054
		4.1.2 Ownership & activities	0.023
		4.1.3 Representation on committee	0.023
	4.2 Maintenance committee/caretaker	4.2.1 Existence	0.025
		4.2.2 Functioning	0.025
	4.3 Coordination and linkage	4.3.1 With local authorities	0.025
4.3.2 Training and external support		0.025	



**Table 3: Score Distribution (%) to determine sustainability status**

Typical five point grading nomenclature	Score Distribution for different grading (%)			Sustainability status
	5-point	4-point	3-point	
Excellent	80-100	70-100	70-100	Sustainable
Very Good	70-79			
Good	50-69	50-69	30-69	Partially sustainable
Fair	30-49	30-49		
Poor	<30	<30	<30	Not sustainable

Figure 3 is a flow chart which demonstrates the main criteria used to assess sustainability of the kiosks. It also shows the thirteen main variables and twenty six sub variables. The cut-off point to determine whether a water scheme is unsustainable, partially sustainable or sustainable is also indicated.

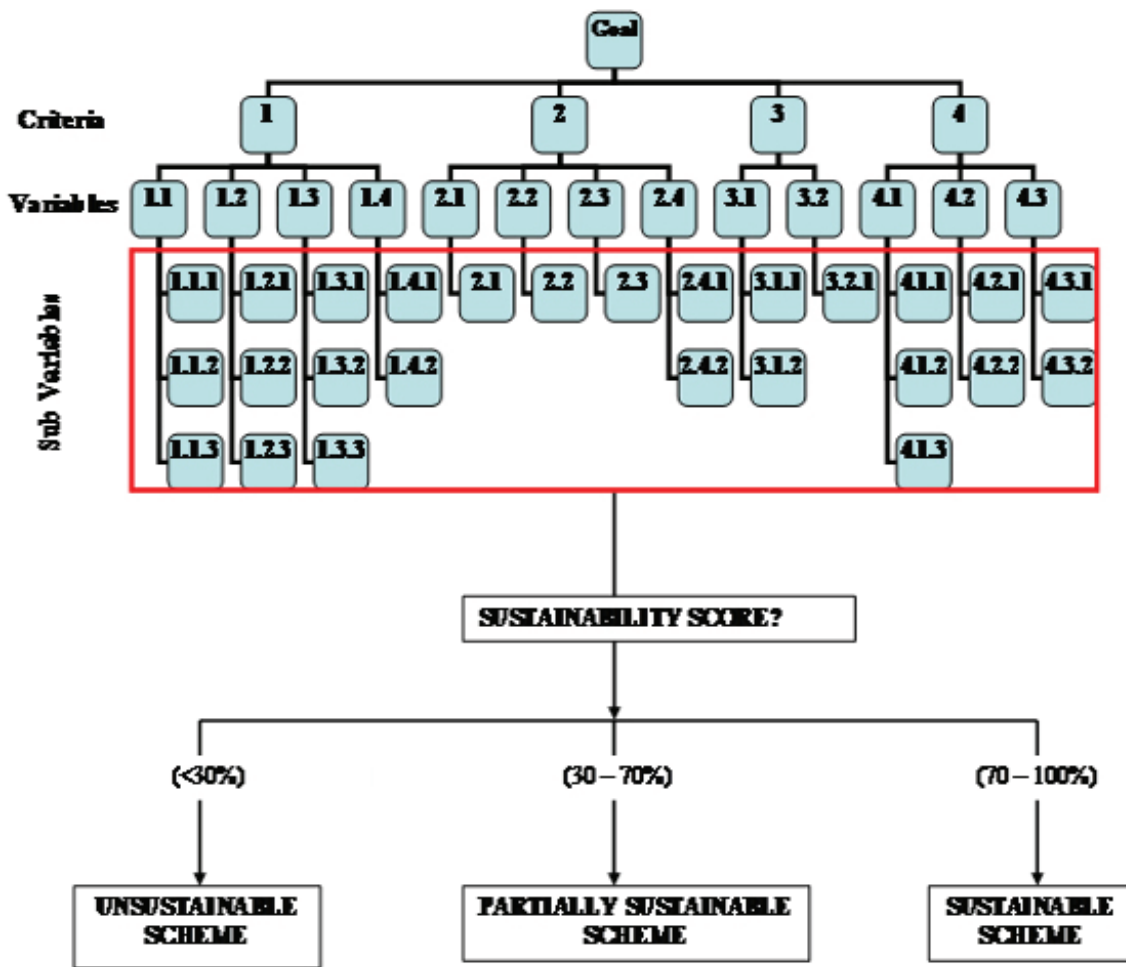

**Figure 3: Flow chart of the main criteria, variables, sub variables and sustainability score cut-off point**

### 2.3 Sampling Procedure

For each study area, Table 4 gives kiosk data i.e. kiosk population, kiosks that were functional and kiosks that were used in this study. This study used face to face informant interviews, structured questionnaires, focus group discussions and observations during site visits. Thirty percent sample of the total population was considered per study area. Hopkins (2002) suggests that a 30% sample of the population is effective for data analysis in populations that are 1000 and below. Random samples were used to determine which water kiosks to include in the respective areas. This technique is a probability technique and is based on the proper knowledge of the area of study by the researcher (Marshall, 1996).

**Table 4: Water Kiosk data for the study areas**

Name of LIA	Total No. of kiosks	No. of functional Kiosks	No. of Kiosks sampled
Bangwe	49	27	9
Chilomoni	53	47	15
Nancholi	24	24	8
Kachere-Nkolokoti	75	75	23

At every kiosk, a kiosk attendant and at least five water users, depending on their availability, were interviewed.

### 2.4 Data collection and Analysis

To collect data, this study used informant face-to-face interviews, structured questionnaires, focus group discussions and observations during site visits.

During face-to-face interviews, a household structured questionnaire was used to collect social, financial and institutional information from the water users. Data collected from these water users include the use of the water facility, level of community participation, social inclusion and equity and availability and use of operation and maintenance fund. In addition, data on the existence, scheme ownership and representation of water users' committee was also collected. Additional questionnaire collected technical data from BWB. This included the water distribution systems used in the study areas, capacity of the feeder storage tanks and their elevation with respect to the water intake and general management of the water kiosks through Kiosks Management Unit.

Observations made during site visits captured significant technical and institutional data such as the physical condition and functioning of the system, source yield as well as coordination between water users and their local leaders. A checklist schedule was used to collect data on other technical aspects of the scheme such as the water quality.

The focus group discussions were held with water users' committee members. A discussion guide was used to collect data on views on sustainability and participation. Significant information obtained during these discussions was to do with management of these water kiosks.

### 3.0 Results and discussions

A summary of study results together with the final composite sustainability scores is presented in Table 5.

From the table, the sustainability score for Bangwe was found to be 54.2%, Chilomoni 66.7%, Kachere-Nkolokoti 60.1% and Nancholi 67.2%; thus all water kiosks are therefore partially-sustainable. It was observed that many kiosks in all the study areas had problems to maintain design flow with Bangwe (29%) and Kachere-Nkolokoti (28%) being the worst. Other contributing factors include inadequate design of feeder tanks for all study areas with Bangwe (44%), Chilomoni (49%), Kachere-Nkolokoti (58%) and Nancholi (52%). The lower capacity of the system to meet additional demand was also noted to contribute significantly with Bangwe registering 29%, Chilomoni 47%, Kachere-Nkolokoti 28% and Nancholi 45%. Due to technical problems highlighted above, many users opt for other water sources such as private taps thereby compromising the aim and objectives of which water kiosks were implemented. Of the four study areas, it was found that Bangwe is the least sustainable due to reasons highlighted above whereas Nancholi is the most sustainable. This is because Nancholi has a good

financial and institutional governance structures.

The above findings concur favourably with findings of a study on sustainability of gravity fed water supply schemes (Zuzani, 2012), where it was discovered that 50% of the water schemes in rural Malawi were partially sustainable. These findings also agree with findings of the field Note 30368 for the Kibera water kiosks study where kiosk owners expressed dissatisfaction with the availability of water and cited interruptions in supply and irregular flow as the key problems (Kariuki and Gikaru, 1997). A study by Spaling et al, 2014 on how three sustainability factors (water supply, regulatory policy, local management) are affecting the sustainability of a community water supply project in Kenya also found that after 10 years the project is at a threshold of sustainability – it may yet fail. Additional withdrawals from new projects, which were not taken into consideration at project conception, are threatening systems and wasteful practices within the distribution systems. Water losses of 40-60% between reservoir and tap are common (Tolba and El-Kholy, 1992) and figures as high as 65% are reported, due to old, leaky pipe networks. Currently, Blantyre Water Board has a non-revenue water rate of about 48%.

**Table 5: Results of sustainability scores for each water scheme**

Sub Variable	Weight	Total scores for individual LIA			
		Bangwe	Chilomoni	Kachere-Nkolokoti	Nancholi
1.1.1 Reliability, adequacy,	0.054	3.3	3.3	3.3	3.3
1.1.2 Water quality at source	0.023	1.7	1.7	1.7	1.7
1.1.3 Accessibility, chance of contamination & conflict	0.023	1.6	1.6	1.6	1.6
1.2.1 Design adequacy, site &	0.008	0.4	0.4	0.5	0.4
1.2.2 Condition & functionality of					
1.2.3 Natural threat to physical system	0.054	2.5	2.9	3.2	2.7
	0.038	2.1	2.1	2.1	2.1
1.3.1 Maintaining design flow	0.120	3.5	6.7	3.4	7.1
1.3.2 Water quality	0.040	2.9	2.9	2.9	2.9
1.3.3 Surrounding condition/Drainage system	0.040	2.9	2.9	2.8	2.8
1.4.1 Waterfetching time	0.070	2.0	5.5	3.2	5.5
1.4.2 Status of meeting addition	0.030	0.9	1.4	0.8	1.4
2.1.1 Status of use by targeted population	0.100	2.3	4.2	3.5	4.0
2.2.1 Decision making and O&M	0.050	2.7	3.0	3.2	3.4
2.3.1 Mitigation measures and	0.050	3.8	3.8	3.8	3.8
2.4.1 Inclusion (ethnic group)	0.031	3.1	3.1	3.1	3.1
2.4.2 Equity (men, women)	0.019	1.6	1.9	1.5	1.9
3.1.1 Establishment of O&M fund	0.025	2.2	1.7	1.8	1.7
3.1.2 Regularity and Transparency	0.015	0.9	1.1	1.1	1.1
3.2.1 Use of savings / surplus	0.010	0.8	0.8	0.8	0.8
4.1.1 Existence, functioning and	0.054	4.4	4.4	4.4	4.4
4.1.2 Ownership & activities	0.023	1.6	1.7	1.7	1.7
4.1.3 Representation on	0.023	2.2	2.3	2.3	2.3
4.2.1 Existence	0.025	2.5	2.5	2.5	2.5
4.2.2 Functioning	0.025	1.6	1.8	1.8	1.7
4.3.1 With local authorities	0.025	1.8	1.8	1.8	1.8
4.3.2 Training and external	0.025	1.3	1.2	1.3	1.5
<b>COMPOSITE SUSTAINABILITY SCORES</b>		<b>54.2%</b>	<b>66.7%</b>	<b>60.1%</b>	<b>67.2%</b>

#### 4.0 Conclusions and recommendations

Study results have shown that water kiosks in low-income areas of Blantyre City, with case studies of Bangwe, Chilomoni, Kachere-Nkolokoti and Nancholi, are partially-sustainable. Of the four study areas, Bangwe is found to be the least sustainable whereas Nancholi is the most sustainable. Major problem significantly contributing to partial sustainability are mainly technical. These include problems to maintain design flow, inadequate design of feeder tanks for all study areas as well as the lower capacity of the system to meet additional demand. Areas that have water kiosks that are relatively more sustainable have good financial and institutional governance

structures.

In order to ensure full sustainability of the use of water kiosks in Blantyre City, it is therefore recommended that BWB should increase its production capacity by repairing or replacing worn out pumps and/or replacing of worn out pipes which cause water losses due to leakages and pipe bursting. This study also recommends that for proper operation, management and maintenance of water kiosks, there is need to have robust financial and institutional governance structures by all concerned stakeholders.

### References

1. Chirwa E. and Junge N. 2007, Poverty and social impact analysis, private sector participation in the distribution and management of water services: A study of low income areas in Blantyre and Lilongwe, Ministry of economic planning and development, Ministry of Irrigation and Water Development.
2. Government of Malawi (GOM), 2006, Malawi Growth and Development Strategy: from poverty to prosperity 2006-2011, Lilongwe, Malawi.
3. GTZ,. 2009, Case study: Water kiosks. How the combination of low-cost technology, pro-poor financing and regulation leads to the scaling up of water supply service provision to the poor.
4. Hopkins W.G. 2002, Quantitative data analysis, Sports Science 6, Auckland University of Technology, Auckland 1020, New Zealand.
5. Kariuki M. and Gikaru L. 1997, The Water Kiosks of Kibera, Nairobi, Kenya.
6. Marshall M.N. 1996, Sampling for Qualitative Research. Family Practice; 13(6), pp. 522-526.
7. Panthi, K. and Bhattarai, S. 2008, A framework to Assess Sustainability of Community based Water Projects using Multi-Criteria Analysis. First International Conference on Construction In Developing Countries (ICCIDC-I), August 4-5, 2008, (pp. 464-472) Karachi, Pakistan.
8. Spaling H., Brouwer G. and Njoka. J. 2014, Factors affecting the sustainability of a community water supply project in Kenya. Development in Practice Journal, 24(7), pp. 797-811.
9. Tolba M.K. and El-Kholy O.A., 1992, The World Environment 1972-1992: Two decades of challenge. UN Environment Programme, Nairobi, Kenya.
10. Zuzani P.N., Ackim R. and Kalulu K. 2013, Sustainability Of Piped Water Supply Schemes In Rural Malawi Through Community Management, Journal of Basic and Applied Scientific Research. 3(10), pp.113-118.

## Centre for Water, Sanitation, Health and Appropriate Technology Development (WASHTED)

Access to safe drinking water and adequate sanitation is a fundamental right and condition of basic health. Provision of these is a priority of the Malawi Poverty Reduction Programme. In Malawi access to improved water supply is fairly good in general despite having some pockets with inadequate and unimproved sources. Sanitation is however, lagging behind particularly in unplanned urban settlements and rural areas. Poor water and sanitation provision is one of the reasons the country's health indicators are among the worst in the world. The Centre for Water, Sanitation, Health and Appropriate Technology Development (WASHTED) was established at the University of Malawi on 11th April 2003 to champion action research in water, sanitation and health through development, adoption, adaptation and employment of appropriate technology. WASHTED is a semi-autonomous unit within the Faculties of Engineering and Applied Sciences. The Centre aims to build capacity in the field of Water Supply, Sanitation, Health, and Appropriate Technology Development in Malawi. The Centre is headed by a Director who is answerable to a Steering Committee (SC). The composition of the SC is made up of representatives from a range of national and international collaborating partners.

WASHTED offers the following services;

1. Training for personnel in water supply, sanitation and hygiene by offering appropriate courses targeting the needs of participants.
2. Conducting research and consultancy in a wide range of areas including water quality, pollution monitoring, and Integrated Water Resources Management,
3. Development and adoption of technologies appropriate to the local environment through research and capacity building in local communities. These include sanitation systems as well as water retrieval systems and the procurement of spare parts.
4. House a resource centre for use by interested parties covering all areas of water, sanitation and environmental health.
5. Networking and Information Service in water, sanitation health & appropriate technology.
6. Provision of safe water through a borehole



### Our Vision

To be a resource centre for capacity building in water and sanitation, and environmentally sound and sustainable development and management of water resources in Malawi.

### Mission Statement

The mission of WASHTED is to contribute towards the objectives of the Millennium Development Goals, the World Summit on Sustainable Development targets with regard to water and sanitation in Malawi, and the Malawi Growth and Development Strategy.

### Collaborating Partners

WASHTED has a number of collaborating partners throughout the world who are experts in the fields of water, sanitation and environmental health. Some of these partners are;

University of Malawi Research Centres Committee, University of Strathclyde (UK), Lappeenranta University

of Technology (Finland), British Council (DFID), Malawi, Commonwealth Scholarship Commission (UK), Ministry of Irrigation and Water Development (Malawi), Ministry of Health and Population (Malawi), UNICEF Malawi, International Network Training (Africa), IRC International Water and Sanitation Centre (Holland), Water, Engineering and Development Centre (WEDC) (UK), Institute of Water and Sanitation Development (Zimbabwe), Global Water Partnership, Water Supply and Sanitation Collaborative Council, Water and Sanitation Program (World Bank), WaterNet (Zimbabwe).

### **MPhil Programme accepted 13 candidates**

The Malawi Renewable Energy Project under the auspices of WASHTED has 13 MPhil candidates researching in the following broad thematic areas;

<i>MPhil</i>	<i>Topic Area</i>
1	Financing Model for Micro-Hydro
2	Profile and Analysis of the Market for Off-grid C-B Solar PV Systems in Malawi
3	Assessing the Functionalities and Market for Solar PV in Malawi
4	Biogas and Organic Fertilizer Production
5	Scaling Up Energy Efficient Cook stoves
6	Assessment of Biogas Technical Model Performance in Malawi
7	Assessment of the Impact of Rural Stand Alone PV Systems (SAPS)
8	Community Solar PV Component Cost, Availability and Alternatives
9	Low Cost Design Methods for Micro Hydro Generation - A Case of Bondo Micro Hydro Station in Mulanje
10	Impact of Climate Change on the Generation Profile of Micro Hydro Micro Grid. Kavuzi Micro Hydro Power Plant
11	Opportunities for Small and Micro Hydro Power in Malawi Rural Areas: Promoting Public Private Partnership Approach
12	Alcohol/Fusel Oil Blend for Efficient Cook stoves
13	Mini Micro Grids

## MASTER OF SCIENCE IN INFRASTRUCTURE DEVELOPMENT AND MANAGEMENT

The Malawi Polytechnic, a constituent college of the University of Malawi, offers a Master of Science in Infrastructure Development and Management degree aimed at equipping graduates with advanced knowledge, skills and competences on economic, scientific, technical, legal, communication, management and social theories, principles, concepts and practices to enable the graduates to critique and apply them in infrastructure development and management. IDM is a multidisciplinary programme covering such disciplines as power and energy, environment, transportation, public works, water and sanitation, and information and communication technologies. It draws directly from undergraduate programmes uniquely offered at the Malawi Polytechnic in the Faculties of Engineering, Applied Sciences and Built Environment.

### Who should enroll?

IDM is designed for graduates and/or professionals who are pursuing or intend to pursue a career in infrastructure development and management, project management or infrastructure development and programme coordinators in either the public, civil society or private sector. The programme, therefore, will appeal to a wide range of graduates, including those with degrees in fields of sciences, engineering, urban, district and regional planning, architecture and surveying.

### Programme duration

The recommended duration for a full-time MSc IDM degree programme is 4 semesters and 6 semesters for part-time MSc IDM. The postgraduate committee can however give an extension up to 2 semesters for full time students and 4 semesters for part time students.

### Programme Fees

Tuition fee is US\$4,500 payable in two instalments.

### Programme structure

The MSc IDM degree programme is divided into two parts: coursework and dissertation. Both parts must be passed for the award of an MSc in IDM degree. Coursework comprises four (4) core modules and six (6) optional modules.

<i>Compulsory Modules</i>	<i>Optional modules</i>
Research methodology	Water and Sanitation Systems
Environment and Sustainable Development	Sustainable Energy Systems
Project Management	Information and Communication Technology
Infrastructure Assets Management	Public Works Systems
	Transportation Systems
	Land Planning and Management

Each student must complete all 4 core modules and at least 4 optional modules. In addition, students are required to submit a research proposal and a dissertation at the end of the third and fourth semesters, respectively. The research can take the form of experimental work, modelling, survey and case studies in the area of infrastructure development and management.

### Admission criteria

To be admitted into the MSc-IDM degree programme, candidates must have a relevant bachelor's degree with at least a strong pass from any recognised institution of higher learning. Candidates may be interviewed

## **MJASI Information for contributors**

### **1.0 Introduction**

MJASI (the Malawi Journal of Applied Sciences and Innovation) is an international biannual peer review open access full publication of The Faculty of Applied Sciences at the Polytechnic - University of Malawi. MJASI publishes original research and review articles on various aspects of Applied Sciences. Authors should submit their contributions electronically through the Journal's email address [mjasi@poly.ac.mw](mailto:mjasi@poly.ac.mw).

### **2.0 Before you begin**

#### **2.1 Ethical considerations**

All authors are requested to disclose any actual or potential conflict of interest including any financial, personal or other relationships with other people or organizations within three years of beginning the submitted work that could inappropriately influence, or be perceived to influence, their work. The participants need to give consent, to the research being carried out and this has to be indicated in the study.

#### **2.2 Submission declaration and verification**

Submission of an article implies that the work described has not been previously published (except in the form of an abstract or as part of a published lecture or academic thesis or unpublished conference proceedings), that it is not under consideration for publication elsewhere, that its publication is approved by all authors and tacitly or explicitly by the responsible authorities where the work was carried out, and that, if accepted, it will not be published elsewhere in the same form, in English or in any other language, including electronically without the written consent of the copyright-holder.

#### **2.3 Copyright**

Upon acceptance of an article, authors will be asked to complete a 'Journal Publishing Agreement'. Acceptance of the agreement will ensure the widest possible dissemination of information. An e-mail will be sent to the corresponding author confirming receipt of the manuscript together with a 'Journal Publishing Agreement' form or a link to the online version of this agreement. Subscribers may reproduce tables of contents or prepare lists of articles including abstracts for internal circulation within their institutions. Permission of the Publisher is required for resale or distribution outside the institution and for all other derivative works, including compilations and translations. If excerpts from other copyrighted works are included, the author(s) must obtain written permission from the copyright owners and credit the source(s) in the article.

All articles will be checked for plagiarised materials using online software such as Turnitin.com. Articles that breach the threshold of 20% shall be rejected immediately. As such, authors are encouraged to check that direct citations constitute no more than 20% of their articles.

#### **2.4 Open access**

This is an open access journal making published articles freely available to all. Authors retain many rights, including the right to post a revised personal version of their article on their own website.

#### **2.5 Language**

Please write your text in good English (preferably British) usage is accepted, but not a mixture of these).

#### **2.6 Submission**

Submission to this journal proceeds totally online. Optionally, articles may also be submitted by using the journal email address if contributors are finding problems with our online submission system. All correspondence, including notification of the Editor's decision and requests for revision, will take place by e-mail.

### **3.0 Manuscript preparation**

#### **3.1 Article format**

Manuscripts must be submitted only in English and authors should check that correct grammar and proper terminology have been used. Manuscripts should be typed in Arial font 11pt. and in MS-word 1997 – 2003 format in one column with 2.54 cm margin at each side. Manuscript must be accompanied by a covering letter including title and author(s) name. The manuscript should be single spaced. The article should be structured as follows; title, names of authors and their affiliations, abstract, key words, introduction, materials and methods, results and discussion, conclusions and recommendations, references and where applicable appendices. For maths papers, authors should not use extremely advanced software for the write-up. The maximum page numbers are as follows (Authors should strictly adhere to this);

- Original research papers (10 pages maximum including tables, figures and references)
- Review papers (15 pages maximum including tables, figures and references)



## **3.2 Article structure**

### **3.2.1 Subdivision - numbered sections**

Authors should divide their articles into clearly defined and numbered sections. Main headings (Heading 1) should be numbered 1.0 etc and should be Arial font size 14, the next hierarchy of headings (Heading 2) should be numbered 1.1 etc and should be Arial font size 12, the next level (Heading 3) should be numbered 1.1.1 etc and should be Arial font size 12 and in italics. If the headings go beyond level three, then the next level should not be numbered. Each heading should appear on its own separate line.

### **3.2.2 Paragraphs**

The line spacing between paragraphs should be 1.5. Paragraphs should not be indented.

### **3.2.3 Title**

The title should be concise and informative. Avoid abbreviations and formulae where possible. The title should be in upper case, with a maximum of 18 words and in Arial font size 14.

### **3.2.4 Author names and affiliations**

Where the family name may be ambiguous (e.g., a double name like van Persie), please indicate this clearly. Present the authors' affiliation addresses below the names. Indicate all affiliations with a lower-case superscript letter immediately after the author's name (s) and in front of the appropriate address. In addition to this, all authors should provide an email address. The corresponding authors name should be marked by an asterisk. The author's names should appear in the way they have contributed to the work being submitted.

### **3.2.5 Abstract**

A concise and factual abstract is required. The abstract should state briefly the purpose of the research, the principal results and major conclusions. An abstract is often presented separately from the article, so it must be able to stand alone. References should be avoided. Also, non-standard or uncommon abbreviations should be avoided, but if essential they must be defined at their first mention in the abstract itself. The abstract should be 150 to 250 words.

### **3.2.6 Keywords**

Immediately after the abstract provide four to six keywords. Do not use abbreviations as key words. Keywords will be used for indexing purposes.

#### **3.2.7 Introduction**

State the objectives of the work and provide an adequate background, avoiding a detailed literature survey or a summary of the results.

### **3.2.8 Materials and methods**

This section should provide clear information such that it should be possible for another individual to repeat the work. The section should provide information on sampling procedures used, research designs and the statistics used in data analysis.

### **3.2.9 Results and discussion**

Results should be clear and concise. The discussion should exhaustively explore the significance of the results of the work.. Authors should avoid extensive citations and discussion of published literature.

### **3.2.10 Conclusions**

The main conclusions of the study may be presented in a short stand-alone conclusions section.

### **3.2.11 Acknowledgements**

Collate acknowledgements in a separate section at the end of the article before the references and do not, therefore, include them on the title page, as a footnote to the title or otherwise. List here those individuals who provided help during the research (e.g. sponsors of the work, supervisors, language help providers, writing assistance or proof reading individuals, etc.).

### **3.2.12 Nomenclature and units**

Follow internationally accepted rules and conventions: use the international system of units (SI). If other quantities are mentioned, give their equivalent in SI.

### **3.2.13 Math formulae**

Present simple formulae in the line of normal text where possible and use the solidus (/) instead of a horizontal line for small fractional terms (e.g., a/b). In principle, variables are to be presented in italics. Powers of e are often more conveniently denoted by exp. Number consecutively any equations that have to be displayed separately from the text (if referred to explicitly in the text).

### 3.2.14 Figure captions

Ensure that each illustration has a caption. A caption should comprise a brief title and a description of the illustration. Provide a key to a figure if necessary. Place labels below the figures. Figures must appear in the text nearest to where they are first mentioned and in the order in which they are referred to in the text. The number of figures should not exceed 4.

### 3.2.15 Tables

Number tables consecutively in accordance with their appearance in the text and must appear in the text nearest to where they are first mentioned and in the order in which they are referred to in the text. Minimise the use of tables and ensure that the data presented in tables does not duplicate results described elsewhere in the article. Labels should be placed above the tables. The number of tables should not exceed five.

## 4.0 References

### 4.1 Citation in the text

*Table 1 shows how citation of different sources should be done in the text*

To cite a direct quotation	Write the text word for word and place quotation marks at the beginning and end of the quotation. The author, date and page number must be included.  "Australia is a settler society" (Hudson & Bolton, 1997, p. 9).
To cite a paraphrase or a short summary of an author's words or ideas	Restate the original words/ idea in your own words. The author, date and page number(s) must be included.  Wartime textile rationing was imposed through a coupon system, which meant garments now had two costs: their value in monetary units and in coupons (McKernan, 1995, p. 152).
To reference the overall content of a work	You do not need to include page numbers because it is the entire work you are referring to: Larsen and Greene (1989) studied the effects of pollution in three major cities...
To cite a quotation or idea from an author who attributes it to another source	You must acknowledge both sources in your text:  Graham Gibbs, in his 1981 study into student learning wrote that "because students are aware of their tutor's mastery of the subject matter, it is quite common for them to assume that their reader has no needs at all" (Gibbs 1981, p. 39, cited in Bowden & Marton, 1998, p. 35).
To refer to more than one work	Separate the references either with a semicolon or the word "and"  (Entwistle, 1977; Haddon, 1969) or: Entwistle (1977) and Haddon (1969) both demonstrated ...

To cite more than one author	Include both names in the order in which they appear on the title page:  (Gerster & Basset, 1987) or: Gerster and Basset (1987) assert that ...
To cite more than three authors.	Use the surname of the first author and et al. ('and others') in the text, et al should appear in italics:  Leeder et al. (1996, p. 78) argued ... or: (Leeder et al. 1996)
To cite more than one work by the same author	Arrange citations in chronological order:  (Smith, 1981, 1984, 1985)
To cite authors with the same family name who have published in the same year	Use their initials to indicate different people:  The theory was first developed early 20th century (Smith, A K 1979) but later many of its elements were refuted (Smith, J A 1979).
To cite an author who published more than one work in the same year	Attach an a, b, c, d etc. after the year: Dawkins (1972a, 1972b) completed a number of studies on...
To cite a part of a publication contributed by someone other than the main author	For example, a preface, introduction or foreword contributed by someone other than the author of the publication:  Drabble (in Bronte 1978) suggests ....

## 4.2 Referencing

1. Write the list in alphabetical order: put the first author's last name first and then his/her initials. Include the names and initials of all authors. Arrange any references with the same author by the year of publication, beginning with the oldest.
2. Titles should be italicised for books, reports and conference proceedings. For journal articles, the title of the journal (not the title of the journal article) should be printed in italics.
3. Capitalise the first letter of each author's last name and each initial. Also capitalise the first letter of the publication title written in italics, the first letters of all main words in the title of a journal and all first letters of a place name and publisher.

Table 2 shows how reference list for different sources should be done.

**Table 2: Reference List Format**

Book	Author's Family Name, Initials. Year, Title, edition, Publisher, Place of publication.  Liebowitz, J., Agresti, W. & Djavanshir, G. R. 2006, Communicating as IT Professionals, Pearson Prentice Hall, Upper Saddle River, USA.
------	---

<p>Edited Book</p>	<p>Editor's Family Name, Initials. (ed.) Year, Title, edition, Publisher, Place of publication.</p> <p>Haag, S. &amp; Cummings, M. (eds) 2008, Information Systems Essentials, 2 edn, McGrawHill Irwin, New York.</p>
<p>Online Book</p>	<p>Author's Family Name, Initials. Year, Title, edition, Publisher, Place of publication, viewed date, &lt;URL&gt;</p> <p>Adelstein, T. &amp; Lubanovic, B. 2007, Linux System Administration, Safari Tech Books Online, Boston, USA, viewed 17/3/2009, &lt;<a href="http://proquest.safaribooksonline.com.ezproxy.lib.uts.edu.au/9780596009526">http://proquest.safaribooksonline.com.ezproxy.lib.uts.edu.au/9780596009526</a>&gt;.</p>
<p>Book chapter</p>	<p>Chapter Author's Family Name, Initials. Year, 'Chapter title', in Editors' Initials, Editors' Name (ed.), Title, edition, Publisher, Place of publication, pages of chapter.</p> <p>Weber, I., Yow, K.C. &amp; Soon, B.-H. 2005, 'Tuning in to students' mobile learning needs: a Singapore interactive initiative', in A. Kukulska-Hulme &amp; J. Traxler (eds) Mobile Learning: A Handbook for Educators and Trainers, Routledge, London, pp. 150-156.</p>
<p>Journal article</p>	<p>Author's Family Name, Initials. Year, 'Article title', Journal Title, volume number, issue number, page number(s).</p> <p>Ang, L. and Taylor, B. 2005. Managing customer profitability using portfolio matrices. Journal of Database Marketing and Customer Strategy Management 12(5), pp. 298-304.</p>
<p>Electronic journal article</p>	<p>Author's Family Name, Initials. Year, 'Article title', Journal Title, volume number, issue number, page number(s), viewed date, &lt;URL&gt;</p> <p>Merchant, A.T. 2007. Diet, physical activity, and adiposity in children in poor and rich neighbourhoods: a cross-sectional comparison. Nutrition Journal [Online] 6, viewed 10 May 2007, &lt;<a href="http://www.nutritionj.com/content/pdf/1475-2891-6-1.pdf">http://www.nutritionj.com/content/pdf/1475-2891-6-1.pdf</a>&gt;</p>

<p>Conference Paper (no information regarding editorship provided)</p>	<p>Author's Family Name, Initials. Year, 'Paper title', Conference Name, Conference Date, Conference Location, page number(s).</p> <p>Landale, K., Nguyen, P., Hoque, R., Lee, S.K. &amp; Shin, H.K. 2004, 'What UTS Does with Its Old Computers and What They Should Do', Second Australian Undergraduate Students' Computing Conference, 8-10 December 2004, Melbourne, pp. 113-119</p>
<p>Conference Paper (with editor information)</p>	<p>Author's Family Name, Initials. Year, 'Paper title', Conference Name, ed. Editor's Initials, Editor's Family Name, Conference Date, Conference Location, page number(s).</p> <p>Brady, F., Dyson, L.E. &amp; Asela, T. 2008, 'Indigenous adoption of mobile phones and oral culture', Cultural Attitudes towards Technology and Communication, eds F. Sudweeks, H. Hrachovec &amp; C. Ess, 24-27 June 2008, Nîmes, France, pp. 384-398.</p>
<p>Magazine or Newspaper Article (print version)</p>	<p>Author's Family Name, Initials. Year, 'Article title', Name of Newspaper/Magazine (Section), Issue Day and Month, page number(s).</p> <p>Peatling, S. &amp; Malkin, B. 2004, 'Employers face ban on email spying', Sydney Morning Herald, 31 March, p. 17.</p>
<p>Magazine or Newspaper Article (no author given)</p>	<p>'Article title' Year, Name of Newspaper/Magazine (Section), Issue Day and Month, page number(s).</p> <p>'Cisco and IBM hear call of the wild via donation to improve animal care and educate public on endangered animals' 2007, Wireless News, 5 December, p. 1.</p>
<p>Online Magazine or Newspaper Article</p>	<p>Author's Family Name, Initials. Year, 'Article title', Name of Newspaper/Magazine, Issue Day and Month, viewed date, &lt;URL&gt;.</p> <p>Moses, A. 2009, 'Banned hyperlinks could cost you \$11,000 a day', Sydney Morning Herald, 17 March, viewed 18 March 2009, &lt;<a href="http://www.smh.com.au/articles/2009/03/17/1237054787635.html">http://www.smh.com.au/articles/2009/03/17/1237054787635.html</a>&gt;.</p>

Report	<p>Author's Family Name, Initials. [or Name of Issuing Authority] Year, Title, Report Series and Number, Publisher, Place of publication.</p> <p>RTIRC (Regional Telecommunications Independent Review Committee) 2008, Framework for the Future: Regional Telecommunications Review, Commonwealth of Australia, Canberra.</p>
Web page	<p>Author's Family Name, Initials. Year, 'Article title', viewed date, &lt;URL&gt;</p> <p>Thompson, B. 2006. Why the net should stay neutral [Online], viewed 1 May 2007, &lt;Available at: <a href="http://news.bbc.co.uk/1/hi/technology/4594498">http://news.bbc.co.uk/1/hi/technology/4594498</a> &gt;</p>

## **5.0 After acceptance**

### **5.1 Proofs**

One set of page proofs (as PDF files) will be sent by e-mail to the corresponding author or, a link will be provided in the e-mail so that authors can download the files themselves.

### **5.2 Publication process**

Accepted papers will appear online and in a hardcopy version of the journal.